

# SKR



## Caged Ball LM Guide Actuator Model SKR

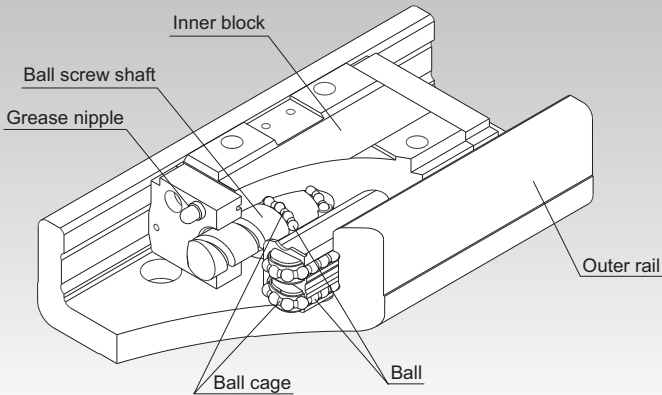

Fig.1 Structure of Caged Ball LM Guide Actuator Model SKR

### Structure and Features

Caged Ball LM Guide Actuator model SKR is a compact actuator that has a inner block consisting of LM blocks and a ball screw nut integrated inside a U-shaped outer rail.

In addition, this model achieves high speed operation, lower noise and longer-term maintenance-free operation by using ball cages in the LM Guide units and the Ball Screw unit. (A ball cage is used only for the LM guide section of models SKR20 and SKR26 and the ball screws are fitted with QZ lubricators.)

#### [4-way Equal Load]

Each row of balls is arranged at a contact angle of  $45^\circ$  so that the rated load on the inner block is uniform under loads applied to the inner block in the four directions (radial, reverse radial and lateral directions). As a result, model SKR can be used in any mounting orientation.

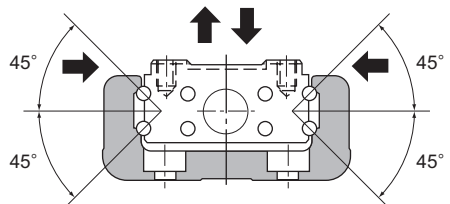

Fig.2 Load Capacity and Contact Angle of Model SKR

**[High Rigidity]**

Use of an outer rail with a U-shaped cross section increases the rigidity with respect to moment and torsion.

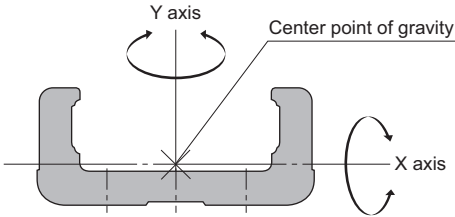

Fig.3 Cross Section of the Outer Rail

Table1 Cross-sectional Characteristics of the Outer rail Rail

Model No.	$I_x$ [mm <sup>4</sup> ]	$I_y$ [mm <sup>4</sup> ]	Mass[kg/m]
SKR20	$6.0 \times 10^3$	$6.14 \times 10^4$	2.6
SKR26	$1.66 \times 10^4$	$1.48 \times 10^5$	3.9
SKR33	$5.35 \times 10^4$	$3.52 \times 10^5$	6.1
SKR46	$2.05 \times 10^5$	$1.45 \times 10^6$	12.6
SKR55	$2.07 \times 10^5$	$2.09 \times 10^6$	13.2
SKR65	$4.51 \times 10^5$	$5.73 \times 10^6$	22.1

$I_x$ =geometrical moment of inertia around X axis  
 $I_y$ =geometrical moment of inertia around Y axis

**[High Accuracy]**

Since the linear guide section consists of 4 rows of circular-arc grooves that enable balls to smoothly move even under a preload, a highly rigid guide with no clearance is achieved. Additionally, variation in frictional resistance caused by load fluctuation is minimized, allowing the system to follow highly accurate feed.

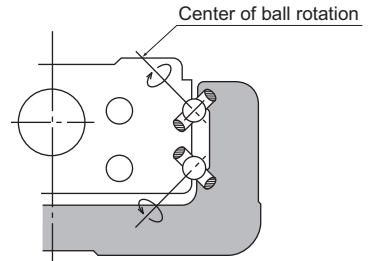

Fig.4 Contact Structure of SKR

**[Space Saving]**

Due to an integral structure where LM Guide units are placed on both side faces of the inner block and a Ball Screw unit is placed in the center of the inner block, a highly rigid and highly accurate actuator with a minimal space is achieved.

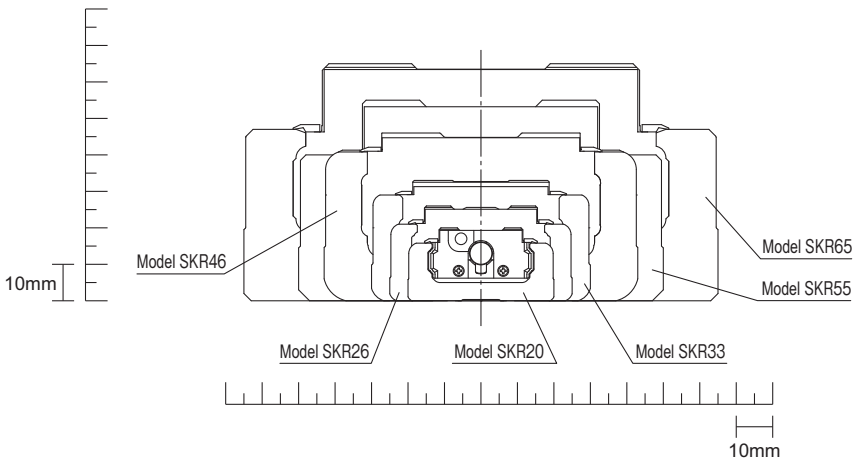

Fig.5 Cross Sectional Drawing

## Caged Ball Technology

### [High Speed]

Model SKR supports a latest high-rotation servomotor ( $6,000 \text{ min}^{-1}$ ) by using a ball cage and is capable of operating at higher speed than the full-ball type model KR.

Models SKR33/55/65 are available in more leads variations to achieve higher speed operation and high leads are available which was not feasible with the model KR.

Model No.	Lead	
	SKR	KR
33	6, 10, 20	6, 10
55	20, 30, 40	20
65	20, 25, 30, 50	25

### [High Lubricity]

Model SKR uses ball cages to eliminate friction between balls and significantly improve torque characteristics. As a result, the torque fluctuation is reduced and superb lubricity is achieved.

Item	Description
Shaft diameter/lead	$\phi 13/10\text{mm}$
Shaft rotation speed	$60\text{min}^{-1}$

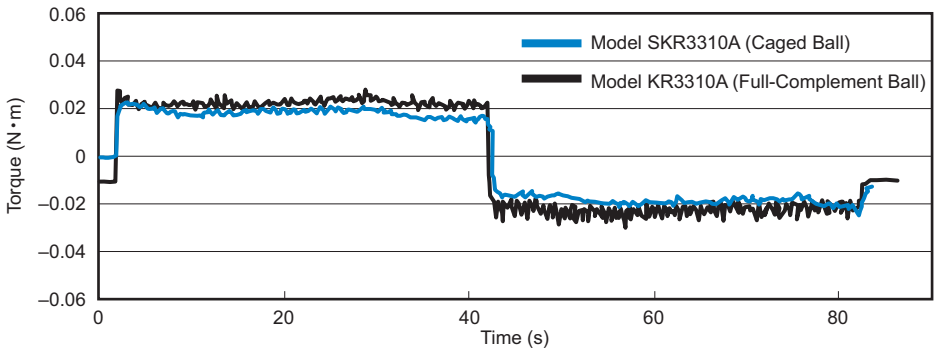

Fig.6 Comparison of Torque Fluctuation between Model SKR and Model KR

### [Low Noise, Acceptable Running Sound]

In model SKR, the use of a ball cage in the LM Guide section and Ball Screw section (excluding models SKR20/26) has eliminated collision noise between the balls. As a result, low noise and acceptable running sound are achieved.

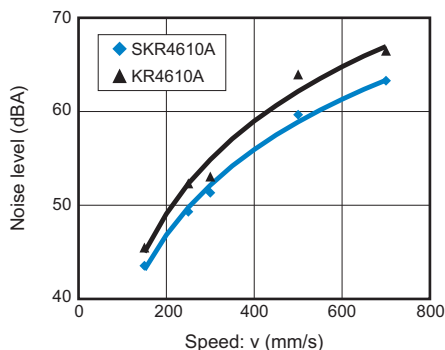

Fig.7 Comparison of Noise between Model SKR4610A and Model KR4610A

### [Long-term Maintenance-free Operation]

With model SKR, the ball cage effect helps increase grease retention and achieve long-term maintenance-free operation.

### [Long service life—3 times]

With model SKR, both the LM Guide unit and the Ball Screw unit have larger basic dynamic load ratings than the full-ball type model KR, and therefore a longer service lives are achieved.

The rated service life is calculated from the following equation.

LM guide unit

$$L = (C/P)^3 \times 50$$

L : Nominal life

C : Basic dynamic load rating (N)

P : Applied load (N)

Ball screw unit

$$L = (Ca/Fa)^3 \times 10^6$$

L : Nominal life (rev)

Ca : Basic dynamic load rating (N)

Fa : Applied axial load (N)

As indicated in the equation above, the greater the basic dynamic load rating, the longer the service life of both the LM Guide unit and the Ball Screw unit.

Table2 Comparison of Basic Dynamic Load Rating between Model SKR and Model KR

Unit: N

Basic dynamic load rating		SKR 20	KR 20	SKR 26	KR 26	SKR 33	KR 33	SKR 46	KR 46	SKR 55	KR 55	SKR 65	KR 65
LM guide unit C	Long type block	6010	3590	13000	7240	17000	11600	39500	27400	55400	38100	74400	50900
	Short type block	—	—	—	—	11300	4900	28400	14000	—	—	—	—
Ball screw unit Ca		660	660	2350	2350	2700	1760	4240	3040	10900	3620	12000	5680

Note) On the SKR20/26, only the LM guide section features a ball cage.

**[Seal]**

Model SKR is equipped with end seals and side seals for dust prevention as standard.

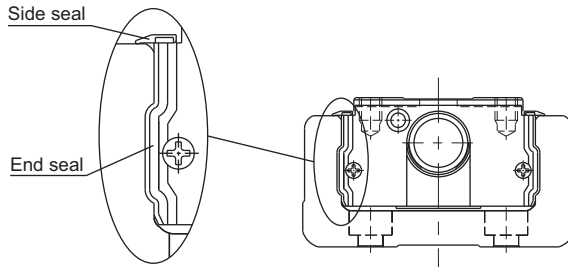

Table3 shows the rolling resistance and seal resistance per inner block (guide section).

Table3 Maximum Resistance Value Unit: N

Model No.	Rolling resistance value	Seal resistance value	Total
SKR20	4.0	0.8	4.8
SKR26	4.5	1.2	5.7
SKR33	3.0	1.7	4.7
SKR46	6.0	2.1	8.1
SKR55	14.0	3.8	17.8
SKR65	20.0	4.1	24.1

## Types and Features

### Model SKR-A (with a Single Long Type Block)

Representative model of SKR.

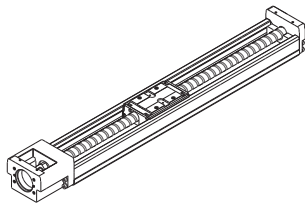

Model SKR-A

### Model SKR-B (with Two Long Type Blocks)

Equipped with two units of the inner block of model SKR-A, this model achieves higher rigidity and higher load carrying capacity.

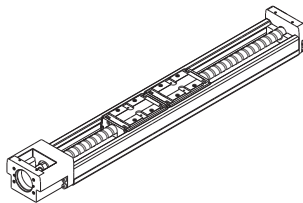

Model SKR-B

### Model SKR-C (with a Single Short Type Block)

This model has a shorter overall length of the inner block and a longer stroke than model SKR-A.

\* With model SKR3320, a short-block type is not available.

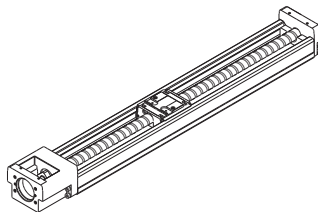

Model SKR-C

### Model SKR-D (with Two Short Type Blocks)

Equipped with two units of the inner block of model SKR-C, this design allows a span between blocks that suits the equipment, thus to achieve high rigidity.

\* With model SKR3320, a short-block type is not available.

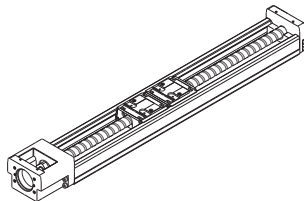

Model SKR-D

## Load Ratings in All Directions and Static Permissible Moment

### [Load Rating]

Caged Ball LM Guide Actuator Model SKR consists of an LM Guide, a Ball Screw and a support bearing.

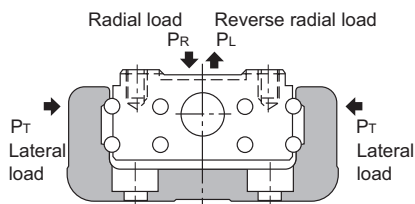

### ● LM Guide Unit

Model SKR is capable of receiving loads in four directions (radial, reverse radial and lateral directions). Its basic load ratings are equal in all four directions (radial, reverse radial and lateral directions), and their values are indicated in Table4.

### ● Ball Screw Unit

Since the inner block is incorporated with a ball screw nut, model SKR is capable of receiving an axial load. The basic load rating value is indicated in Table4.

### ● Bearing Unit (Fixed Side)

Since housing A contains an angular bearing, model SKR is capable of receiving an axial load. The basic load rating value is indicated in Table4.

### [Equivalent Load (LM Guide Unit)]

The equivalent load when the LM Guide unit of model SKR simultaneously receives loads in all directions is obtained from the following equation.

$$P_E = P_R (P_L) + P_T$$

$P_E$  : Equivalent load (N)

: Radial direction

: Reverse radial direction

: Lateral directions

$P_R$  : Radial load (N)

$P_L$  : Reverse radial load (N)

$P_T$  : Lateral load (N)





Table4 Load Rating of Model SKR

Model No.			SKR20		SKR26		SKR33*		
			SKR2001	SKR2006	SKR2602	SKR2606	SKR3306	SKR3310	SKR3320
LM guide unit	Basic dynamic load rating C (N)	Long type block	6010		13000		17000		
		Short type block	—		—		11300	—	
	Basic static load rating C <sub>0</sub> (N)	Long type block	8030		16500		20400		
		Short type block	—		—		11500	—	
	Radial clearance (mm)	Normal grade, high accuracy grade	-0.004 to 0		-0.006 to 0		-0.004 to 0		
		Precision grade	-0.006 to -0.004		-0.007 to -0.006		-0.012 to -0.004		
Ball screw unit	Basic dynamic load rating C <sub>a</sub> (N)	Normal grade, high accuracy grade	660	860	2350	1950	4400	2700	2620
		Precision grade	660	1060	2350	2390			
	Basic static load rating C <sub>0a</sub> (N)	Normal grade, high accuracy grade	1170	1450	4020	3510	6290	3780	3770
		Precision grade	1170	1600	4020	3900			
	Screw shaft diameter (mm)		6		8		13		
	Ball Screw lead (mm)		1	6	2	6	6	10	20
	Thread minor diameter (mm)		5.3	5.0	6.6	6.7	10.8		
	Ball center-to-center diameter (mm)		6.15	6.3	8.3	8.4	13.5		
Bearing unit (Fixed side)	Axial direction	Basic dynamic load rating C <sub>a</sub> (N)	1150		2000		6250		
		Static permissible load P <sub>0a</sub> (N)	735		1230		2700		

\*For use in a special environment or where an axial load (25% or more of the basic dynamic load rating C<sub>a</sub>) is applied, a special type is also available. Contact THK for details.

Note1) The load ratings in the LM Guide unit each indicate the load rating per inner block.

Note2) With model SKR3320, a short-block type is not available.

SKR46*		SKR55			SKR65			
SKR4610	SKR4620	SKR5520	SKR5530	SKR5540	SKR6520	SKR6525	SKR6530	SKR6550
39500		55400			74400			
28400		—			—			
45900		62500			81600			
28700		—			—			
-0.006 to 0		-0.007 to 0			-0.008 to 0			
-0.016 to -0.006		-0.019 to -0.007			-0.022 to -0.008			
4350	4240	10900	7000	6800	12100	12000	8200	7600
6990	7040	17600	11500	9900	21600	22000	14500	12600
15		20			25			
10	20	20	30	40	20	25	30	50
12.5		17.1			22.1			
15.75		20.75			25.75			
6700		7600			13700			
3330		3990			5830			

### [Permissible Moment (LM Guide Unit)]

The Inner block is capable of receiving moment loads in all three (3) directions.

**A2-15** Table 5 shows the permissible static moment in the  $M_A$ ,  $M_B$  and  $M_C$  directions.

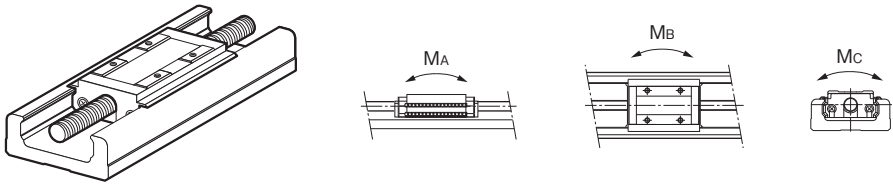

With a single long type block (Model SKR-A)

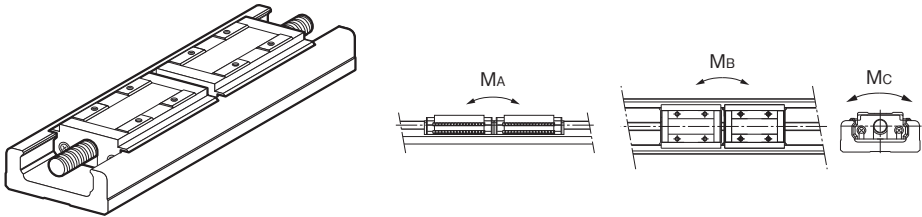

With double long type blocks (Model SKR-B)

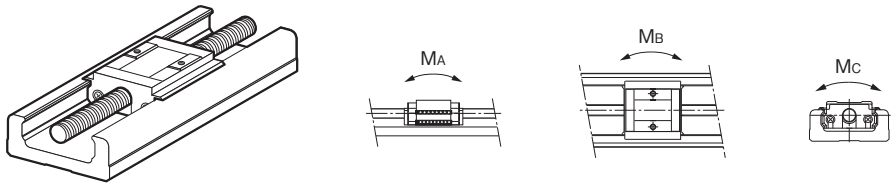

With a single short type block (Model SKR-C)

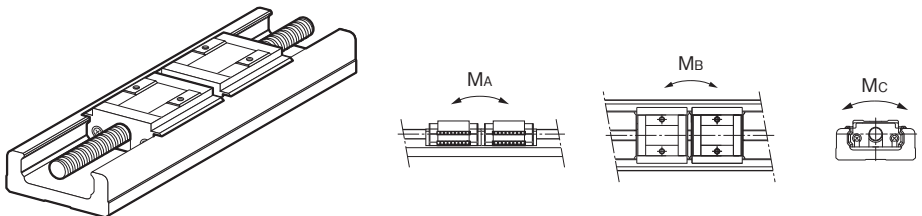

With double short type blocks (Model SKR-D)

Table5 Static Permissible Moments of Model SKR

Unit: N·m

Model No.	Static permissible moment		
	$M_A$	$M_B$	$M_C$
SKR20-A	38	38	98
SKR20-B	207	207	197
SKR26-A	117	117	265
SKR26-B	589	589	530
SKR33-A	173	173	424
SKR33-B	990	990	848
SKR33-C	58	58	240
SKR33-D	390	390	480
SKR46-A	579	579	1390
SKR46-B	3240	3240	2780
SKR46-C	236	236	870
SKR46-D	1460	1460	1740
SKR55-A	923	923	2276
SKR55-B	5125	5125	4552
SKR65-A	1366	1366	3868
SKR65-B	7702	7702	7736

Note1) Symbols A, B, C or D in the end of each model number indicates the inner block size and the number of inner blocks used.

A: With a single long type block

B: With double long type blocks

C: With a single short type block

D: With double short type blocks

Note2) The values for models SKR-B/D indicate the values when double inner blocks are used in close contact with each other.

Note3) Static permissible moment is the maximum moment that can be permitted while the product is stationary.

## Maximum Speeds with Different Strokes

Table6 Maximum speed

Model No.	Ball Screw lead (mm)	Stroke* (mm)		Outer rail length (mm)	Maximum speed (mm/s)		
		Long type block	Short type block		Long type block	Short type block	
SKR20	1	30	—	100	100	—	
		80	—	150	100	—	
		130	—	200	100	—	
	6	30	—	100	600	—	
		80	—	150	600	—	
		130	—	200	600	—	
SKR26	2	60	—	150	200	—	
		110	—	200	200	—	
		160	—	250	200	—	
		210	—	300	200	—	
	6	60	—	150	600	—	
		110	—	200	600	—	
		160	—	250	600	—	
		210	—	300	600	—	
		—	—	—	—	—	
SKR33	6	45	70	150	600	600	
		95	120	200	600	600	
		195	220	300	600	600	
		295	320	400	600	600	
		395	420	500	600	600	
		495	520	600	550	500	
		595	620	700	390	360	
	10	45	70	150	1000	1000	
		95	120	200	1000	1000	
		195	220	300	1000	1000	
		295	320	400	1000	1000	
		395	420	500	1000	1000	
		495	520	600	920	830	
		595	620	700	650	600	
	20	45	—	150	2000	—	
		95	—	200	2000	—	
		195	—	300	2000	—	
		295	—	400	2000	—	
		395	—	500	2000	—	
		495	—	600	1780	—	
		595	—	700	1270	—	
	SKR46	10	190	220	340	1000	1000
			290	320	440	1000	1000
			390	420	540	1000	1000
490			520	640	1000	910	
590			620	740	730	660	
690			720	840	550	500	
790			820	940	430	400	
20		190	220	340	2000	2000	
		290	320	440	2000	2000	
		390	420	540	2000	2000	
		490	520	640	1980	1770	
		590	620	740	1430	1300	
		690	720	840	1080	990	
		790	820	940	840	780	
		—	—	—	—	—	
		—	—	—	—	—	
		—	—	—	—	—	

\*Indicates a stroke when one inner block is incorporated.

Note1) The maximum speed is the value restricted by the permissible rotation speed of the Ball Screw or the permissible speed of the guide, with the motor rotating at 6,000 min<sup>-1</sup>.

Note2) When considering the use of this model at speed higher than the maximum speed indicated above, contact THK.

Model No.	Ball Screw lead (mm)	Stroke* (mm)		Outer rail length (mm)	Maximum speed (mm/s)	
		Long type block	Short type block		Long type block	Short type block
SKR55	20	800	—	980	1100	—
		900		1080	880	
		1000		1180	730	
		1100		1280	610	
		1200		1380	520	
	30	800		980	1650	
		900		1080	1330	
		1000		1180	1100	
		1100		1280	920	
		1200		1380	780	
	40	800		980	2160	
		900		1080	1750	
		1000		1180	1440	
		1100		1280	1210	
		1200		1380	1030	
SKR65	20	790	980	1470	—	
		990	1180	970		
		1190	1380	690		
		1490	1680	450		
	25	790	980	1810		
		990	1180	1200		
		1190	1380	850		
		1490	1680	550		
	30	790	980	2210		
		990	1180	1460		
		1190	1380	1030		
		1490	1680	670		
	50	790	980	3000		
		990	1180	2350		
		1190	1380	1680		
1490		1680	1100			

\*Indicates a stroke when one inner block is incorporated.

Note1) The maximum speed is restricted by the permissible rotation speed of the ball screw, the permissible speed of the guide or 6,000 min<sup>-1</sup> of motor speed.

Note2) When considering the use of this model at speed higher than the maximum speed indicated above, contact THK.

---

## Lubrication

---

Table7 shows standard greases used in model SKR and grease nipple types.

Table7 Types of standard grease and grease nipples used

Model No.	Standard grease	Grease nipple used
SKR20	THK AFA Grease	PB107
SKR26	THK AFA Grease	PB107
SKR33	THK AFB-LF Grease	PB107
SKR46	THK AFB-LF Grease	A-M6F
SKR55	THK AFB-LF Grease	A-M6F
SKR65	THK AFB-LF Grease	A-M6F

## Static Safety Factor

Caged Ball LM Guide Actuator Model SKR consists of an LM Guide, a Ball Screw and a support bearing. The static safety factor and the service life of each component can be obtained from the basic load rating indicated in "Rated load of model SKR" (see Table 4-12).

### [Calculating the Static Safety Factor]

#### ● LM Guide Unit

To calculate a load applied to the LM Guide of model SKR, the average load required for calculating the service life and the maximum load needed for calculating the static safety factor must be obtained first. In particular, if the system starts and stops frequently, or if a large moment caused by an overhung load is applied to the system, it may receive an unexpectedly large load.

When selecting a model number, make sure that the desired model is capable of receiving the required maximum load (whether stationary or in motion).

$$f_s = \frac{C_0}{P_{\max}}$$

$f_s$  : Static safety factor

$C_0$  : Basic static load rating (N)

$P_{\max}$  : Maximum applied load (N)

\*The basic static load rating is a static load with a constant direction and magnitude whereby the sum of the permanent deformation of the rolling element and that of the raceway on the contact area under the maximum stress is 0.0001 times the rolling element diameter.

#### ● Ball Screw Unit/Bearing Unit(Fixed Side)

If an unexpected external force is applied in the axial direction as a result of an inertia caused by an impact or start and stop while model SKR is stationary or operating, it is necessary to take into account the static safety factor.

$$f_s = \frac{C_{0a}}{F_{\max}}$$

$f_s$  : Static safety factor

$C_{0a}$  : Basic static load rating (N)

$F_{\max}$  : Maximum applied load (N)

### [Standard Values for the Static Safety Factor ( $f_s$ )]

Machine type	Load conditions	Minimum Static Safety Factor ( $f_s$ )
General industrial machinery	Without vibration or impact	1.0 to 3.5
	With vibration or impact	2.0 to 5.0

\*The standard value of the static safety factor may vary depending on the load conditions as well as environment, lubrication status, mounting accuracy, and/or rigidity.



## Service Life

### [LM Guide Unit]

#### ● Nominal Life

The nominal life (L) means the total travel distance that 90% of a group of units of the same LM Guide model can achieve without flaking (scale-like pieces on the metal surface) after individually running under the same conditions.

The nominal life of the LM Guide is obtained using the following equation.

$$L = \left( \frac{f_c \cdot C}{f_w \cdot P_c} \right)^3 \times 50$$

L : Nominal life (km)       $f_w$  : Load factor (see Table8 on **A2-21**)  
 C : Basic dynamic load rating (N)       $f_c$  : Contact factor (see Table9 on **A2-22**)  
 $P_c$  : Calculated applied load (N)

- If a moment is applied, calculate the equivalent load by multiplying the applied moment by the equivalent factor indicated in Table10 on **A2-22**.

$$P_m = K \cdot M$$

$P_m$  : Equivalent load (per inner block) (N)

K : Equivalent moment factor

M : Applied moment (N-mm)

(If planning to use the product with a wide inner block span, contact THK.)

If moment  $M_c$  is applied to model SKR-B/D

$$P_m = \frac{K_c \cdot M_c}{2}$$

- If a radial load (P) and a moment are simultaneously applied to model SKR

$$P_E = P_m + P$$

$P_E$  : Overall equivalent radial load (N)

Perform a nominal life calculation using the above data.

#### ● Service Life Time

When the nominal life (L) has been obtained, the service life time is obtained using the following equation (if the stroke length and the number of reciprocations per minute are constant).

$$L_h = \frac{L \times 10^6}{2 \cdot \ell_s \cdot n_1 \times 60}$$

$L_h$  : Service life time (h)

$\ell_s$  : Stroke length (mm)

$n_1$  : Number of reciprocations per minute ( $\text{min}^{-1}$ )

### [Ball Screw Unit/Bearing Unit(Fixed Side)]

#### ● Nominal Life

The nominal life (L) means the total travel distance that 90% of a group of units of the same Ball Screw (bearing) can achieve without flaking after individually running under the same conditions.

The nominal life of the Ball Screw unit/bearing unit (fixed side) is obtained using the following equation.

Table8 Load Factor ( $f_w$ )

$$L = \left( \frac{C_a}{f_w \cdot F_a} \right)^3 \times 10^6$$

- L : Nominal life (rev)  
 $C_a$  : Basic dynamic load rating (N)  
 $F_a$  : Axial load (N)  
 $f_w$  : Load factor (see Table8)

Vibrations/impact	Speed(V)	$f_w$
Faint	Very low $V \leq 0.25\text{m/s}$	1 to 1.2
Weak	Slow $0.25\text{m/s} < V \leq 1\text{m/s}$	1.2 to 1.5
Medium	Medium $1\text{m/s} < V \leq 2\text{m/s}$	1.5 to 2
Strong	High $V > 2\text{m/s}$	2 to 3.5

### ● Service Life Time

When the nominal life (L) has been obtained, the service life time is obtained using the following equation (if the stroke length and the number of reciprocations per minute are constant).

$$L_h = \frac{L \cdot \ell}{2 \cdot \ell_s \cdot n_1 \times 60}$$

$L_h$  : Service life time (h)

$\ell_s$  : Stroke length (mm)

(h)

(mm)

$n_1$  : Number of reciprocations per minute (min<sup>-1</sup>)

$\ell$  : Ball Screw lead (mm)

### ■f<sub>c</sub>: Contact Factor

If two inner blocks are used in close contact with each other with model SKR-B/D, multiply the basic load rating by the corresponding contact factor indicated in Table9.

Table9 Contact Factor (f<sub>c</sub>)

Block type	Contact factor f <sub>c</sub>
Model SKR-B Model SKR-D	0.81

### ■f<sub>w</sub>: Load Factor

In general, machines in reciprocal motion are likely to cause vibration and impact during operation, and it is particularly difficult to accurately determine each of vibration generated during high-speed operation, impact applied during repeated starting and stopping in normal use, etc. Therefore, where the effect of speed vibration is estimated to be significant, divide the basic load rating (C) by an empirically obtained load factor.

### ■K: Moment Equivalent Factor (LM Guide Unit)

When model SKR travels under a moment, the distribution of load applied to the LM Guide is locally large. In such cases, calculate the load by multiplying the moment value by the corresponding moment equivalent factor indicated in Table10.

Symbols K<sub>A</sub>, K<sub>B</sub> and K<sub>C</sub> indicate the moment equivalent loads in the M<sub>A</sub>, M<sub>B</sub> and M<sub>C</sub> directions, respectively.

Table10 Equivalent moment factor(K)

Model No.	K <sub>A</sub>	K <sub>B</sub>	K <sub>C</sub>
SKR20-A	2.34 × 10 <sup>-1</sup>	2.34 × 10 <sup>-1</sup>	8.07 × 10 <sup>-2</sup>
SKR20-B	4.38 × 10 <sup>-2</sup>	4.38 × 10 <sup>-2</sup>	8.07 × 10 <sup>-2</sup>
SKR26-A	1.59 × 10 <sup>-1</sup>	1.59 × 10 <sup>-1</sup>	6.17 × 10 <sup>-2</sup>
SKR26-B	3.18 × 10 <sup>-2</sup>	3.18 × 10 <sup>-2</sup>	6.17 × 10 <sup>-2</sup>
SKR33-A	1.42 × 10 <sup>-1</sup>	1.42 × 10 <sup>-1</sup>	5.05 × 10 <sup>-2</sup>
SKR33-B	2.47 × 10 <sup>-2</sup>	2.47 × 10 <sup>-2</sup>	5.05 × 10 <sup>-2</sup>
SKR33-C	2.39 × 10 <sup>-1</sup>	2.39 × 10 <sup>-1</sup>	5.05 × 10 <sup>-2</sup>
SKR33-D	3.54 × 10 <sup>-2</sup>	3.54 × 10 <sup>-2</sup>	5.05 × 10 <sup>-2</sup>
SKR46-A	9.51 × 10 <sup>-2</sup>	9.51 × 10 <sup>-2</sup>	3.46 × 10 <sup>-2</sup>
SKR46-B	1.70 × 10 <sup>-2</sup>	1.70 × 10 <sup>-2</sup>	3.46 × 10 <sup>-2</sup>
SKR46-C	1.46 × 10 <sup>-1</sup>	1.46 × 10 <sup>-1</sup>	3.46 × 10 <sup>-2</sup>
SKR46-D	2.36 × 10 <sup>-2</sup>	2.36 × 10 <sup>-2</sup>	3.46 × 10 <sup>-2</sup>
SKR55-A	8.12 × 10 <sup>-2</sup>	8.12 × 10 <sup>-2</sup>	2.88 × 10 <sup>-2</sup>
SKR55-B	1.46 × 10 <sup>-2</sup>	1.46 × 10 <sup>-2</sup>	2.88 × 10 <sup>-2</sup>
SKR65-A	7.16 × 10 <sup>-2</sup>	7.16 × 10 <sup>-2</sup>	2.21 × 10 <sup>-2</sup>
SKR65-B	1.27 × 10 <sup>-2</sup>	1.27 × 10 <sup>-2</sup>	2.21 × 10 <sup>-2</sup>

K<sub>A</sub>: Moment equivalent factor in the M<sub>A</sub> direction.

K<sub>B</sub>: Moment equivalent factor in the M<sub>B</sub> direction.

K<sub>C</sub>: Moment equivalent factor in the M<sub>C</sub> direction.

Note) The values for models SKR-B/D indicate the values when double inner blocks are used in close contact with each other.

## Accuracy Standards

The accuracy standard of model SKR is defined in positioning repeatability, positioning accuracy, running parallelism (vertical direction) and backlash.

### [Positioning Repeatability]

Command the position to a given arbitrary point. Measure the position and repeat seven times from the same direction. Record the difference between the largest and smallest values. Conduct the same test at three points: the middle of the stroke, and at both the approximate maximum and minimum positions of travel. Express the maximum difference value of the three measurements divided by 2 with a “±” sign.

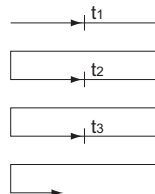

Fig.8 Positioning Repeatability

### [Positioning Accuracy]

Using the maximum stroke as the reference length, express the maximum error between the actual distance traveled from the reference point and the command value in an absolute value as positioning accuracy.

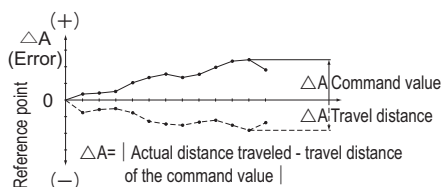

Fig.9 Positioning Accuracy

### [Running of Parallelism (Vertical direction)]

Place a straightedge on the surface table where model SKR is mounted, measure almost throughout the travel distance of the inner block using a test indicator. Use the maximum difference among the readings within the travel distance as the running parallelism measurement.

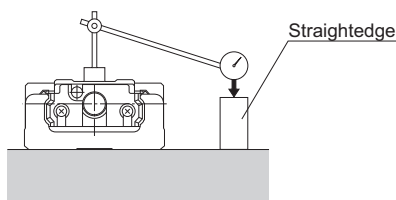

Fig.10 Running of Parallelism

### [Backlash]

Feed and slightly move the inner block and read the measurement on the test indicator as the reference value. Subsequently, apply a load to the inner block from the same direction (table feed direction), and then release the inner block from the load. Use the difference between the reference value and the return as the backlash measurement.

Perform this measurement in the center and near both ends, and use the maximum value as the measurement value.

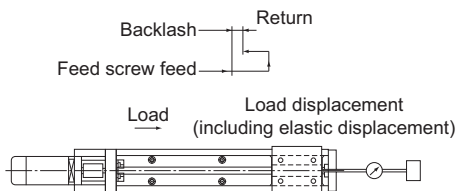

Fig.11 Backlash

The accuracies of model SKR are classified into normal grade (no symbol), high accuracy grade (H) and precision grade (P). Tables below show standards for all the accuracies.

Table11 Normal Grade (No Symbol)

Unit: mm

Model No.	Stroke	Outer rail length	Positioning Repeatability	Positioning Accuracy	Running Parallelism (Vertical Direction)	Backlash	Starting torque (N-cm)
SKR20	30	100	±0.01	No standard defined	No standard defined	0.02	0.5
	80	150					
	130	200					
SKR26	60	150	±0.01	No standard defined	No standard defined	0.02	1.5
	110	200					
	160	250					
	210	300					
SKR33	45	150	±0.01	No standard defined	No standard defined	0.02	7
	95	200					
	195	300					
	295	400					
	395	500					
	495	600					
SKR46	595	700	±0.01	No standard defined	No standard defined	0.02	10
	190	340					
	290	440					
	390	540					
	490	640					
	590	740					
	690	840					
SKR55	790	940	±0.01	No standard defined	No standard defined	0.05	12
	800	980					
	900	1080					
	1000	1180					
	1100	1280					
SKR65	1200	1380	±0.01	No standard defined	No standard defined	0.05	12
	790	980					
	990	1180					
	1190	1380					
	1490	1680	±0.012				15

\*Indicates stroke length when one long-type inner block is incorporated.

Note1) The evaluation method for accuracy standards complies with THK standards.

Note2) The starting torque represents the value when the following grease is used.

Models SKR20 and SKR26 : THK AFA Grease

Models SKR33, SKR46, SKR55 and SKR65 : THK AFB-LF Grease

Note3) If highly viscous grease such as vacuum grease and clean room grease is used, the actual starting torque may exceed the corresponding value in the table. Use much care in selecting a motor.

Note4) Contact THK for accuracy information of units longer than the standard length.

Table12 High Accuracy Grade (H)

Unit: mm

Model No.	Stroke*	Outer rail length	Positioning Repeatability	Positioning Accuracy	Running of Parallelism (Vertical direction)	Backlash	Starting torque (N-cm)
SKR20	30	100	±0.005	0.06	0.025	0.01	0.5
	80	150					
	130	200					
SKR26	60	150	±0.005	0.06	0.025	0.01	1.5
	110	200					
	160	250					
	210	300					
SKR33	45	150	±0.005	0.06	0.025	0.02	7
	95	200					
	195	300					
	295	400		0.10	0.035		
	395	500					
	495	600					
	595	700					
SKR46	190	340	±0.005	0.10	0.035	0.02	10
	290	440					
	390	540					
	490	640		0.12	0.04		
	590	740					
	690	840					
	790	940					
SKR55	800	980	±0.005	0.18	0.05	0.05	12
	900	1080					
	1000	1180		0.25			
	1100	1280					
	1200	1380					
SKR65	790	980	±0.008	0.18	0.05	0.05	12
	990	1180		0.2			
	1190	1380					
	1490	1680		0.28			0.055

\*Indicates stroke length when one long-type inner block is incorporated.

Table13 Precision Grade (P)

Unit: mm

Model No.	Stroke*	Outer rail length	Positioning Repeatability	Positioning Accuracy	Running of Parallelism (Vertical direction)	Backlash	Starting torque (N-cm)
SKR20	30	100	±0.003	0.02	0.01	0.003	1.2
	80	150					
	130	200					
SKR26	60	150	±0.003	0.02	0.01	0.003	4
	110	200					
	160	250					
	210	300					
SKR33	45	150	±0.003	0.02	0.01	0.003	15
	95	200					
	195	300					
	295	400		0.025	0.015		
	395	500					
	495	600					
SKR46	595	700	±0.003	0.03	0.02	0.003	15
	190	340		0.025	0.015		
	290	440					
	390	540					
	490	640					
590	740	0.03	0.02	17			
SKR55	800	980	±0.005	0.035	0.025	0.003	17
	900	1080					
	1000	1180		0.04	0.03		
SKR65	790	980	±0.005	0.035	0.025	0.005	20
	990	1180					
	1190	1380		0.04	0.03		

\*Indicates stroke length when one long-type inner block is incorporated.

Note1) The evaluation method complies with THK standards.

Note2) The starting torque represents the value when the following grease is used.

Models SKR20 and SKR26 : THK AFA Grease

Models SKR33, SKR46, SKR55 and SKR65 : THK AFB-LF Grease

Note3) If harder grease is used, such as vacuum/clean-room grease, the actual starting torque may exceed the values listed.

Note4) Contact THK for information on accuracy for lengths equal to or longer than the standard outer rail.





## Model Number Coding

Model No.	Ball Screw Lead	Inner block type	Stroke	Accuracy
<b>SKR33</b>	<b>10</b>	<b>A</b>	<b>0195</b>	<b>P</b>
①	②	③	④	⑤

SKR20	01 : 1mm	A	0025 : 25mm	No symbol: normal grade H : High accuracy grade P : Precision Grade
SKR26	02 : 2mm	B	0050 : 50mm	
SKR33	06 : 6mm	C	∩	
SKR46	10 : 10mm	D	1490 : 1490mm	
SKR55	20 : 20mm			
SKR65	25 : 25mm			
	30 : 30mm			
	40 : 40mm			
	50 : 50mm			

If "2" (with Bellows) was selected for the cover ⑦, specify a stroke incorporating the bellows (→ **A2-47**).

The available ball screw leads differ depending on the model.

SKR20 : "01", "06"

SKR26 : "02", "06"

SKR33 : "06", "10", "20" (20 mm is available for inner block type A and B only)

SKR46 : "10", "20"

SKR55 : "20", "30", "40"

SKR65 : "20", "25", "30", "50"

With/without a motor	Cover	Sensor	Housing A/ Intermediate Flange																																										
<b>0</b>	<b>1</b>	<b>B</b>	<b>AQ</b>																																										
⑥	⑦	⑧	⑨																																										
<table border="1"> <tr> <td>0: direct-coupled (without a motor)</td> </tr> <tr> <td>1: direct-coupled (with a motor, specified by the customer)</td> </tr> </table>	0: direct-coupled (without a motor)	1: direct-coupled (with a motor, specified by the customer)	<table border="1"> <tr> <td>0: without a cover</td> </tr> <tr> <td>1: with a cover</td> </tr> <tr> <td>2: with a bellows</td> </tr> </table>	0: without a cover	1: with a cover	2: with a bellows	<table border="1"> <tr> <td>0: none</td> <td>10</td> </tr> <tr> <td>1</td> <td>20</td> </tr> <tr> <td>2</td> <td>30</td> </tr> <tr> <td>6</td> <td>40</td> </tr> <tr> <td>7</td> <td>60</td> </tr> <tr> <td>B</td> <td>A0</td> </tr> <tr> <td>E</td> <td>A5</td> </tr> <tr> <td>H</td> <td>A6</td> </tr> <tr> <td>L</td> <td>AM</td> </tr> <tr> <td>J</td> <td>AN</td> </tr> <tr> <td>M</td> <td>AP</td> </tr> <tr> <td></td> <td>AQ</td> </tr> <tr> <td></td> <td>AR</td> </tr> <tr> <td></td> <td>AS</td> </tr> <tr> <td></td> <td>AT</td> </tr> <tr> <td></td> <td>AU</td> </tr> <tr> <td></td> <td>AV</td> </tr> <tr> <td></td> <td>AY</td> </tr> <tr> <td></td> <td>AZ</td> </tr> </table>	0: none	10	1	20	2	30	6	40	7	60	B	A0	E	A5	H	A6	L	AM	J	AN	M	AP		AQ		AR		AS		AT		AU		AV		AY		AZ
0: direct-coupled (without a motor)																																													
1: direct-coupled (with a motor, specified by the customer)																																													
0: without a cover																																													
1: with a cover																																													
2: with a bellows																																													
0: none	10																																												
1	20																																												
2	30																																												
6	40																																												
7	60																																												
B	A0																																												
E	A5																																												
H	A6																																												
L	AM																																												
J	AN																																												
M	AP																																												
	AQ																																												
	AR																																												
	AS																																												
	AT																																												
	AU																																												
	AV																																												
	AY																																												
	AZ																																												
<p>If "0" is selected, a coupling is not attached. If a coupling is required, please indicate so.</p> <p>"1" means that a motor specified by the customer is mounted.</p> <p>For item ⑨, select a housing A/intermediate flange that matches the specified motor.</p>																																													
<p>Several motors by different manufacturers can be mounted. Contact THK for details.</p>																																													

A type with a wrap-around housing A and a motor wrap-around type, which are not contained in the catalog, are also available. Contact THK for details.

# Model SKR20 Standard Type

Model SKR20□□A (with a Single Long Nut Block)

Model SKR20□□B (with Two Long Nut Blocks)

For model number coding, see **A2-28**.

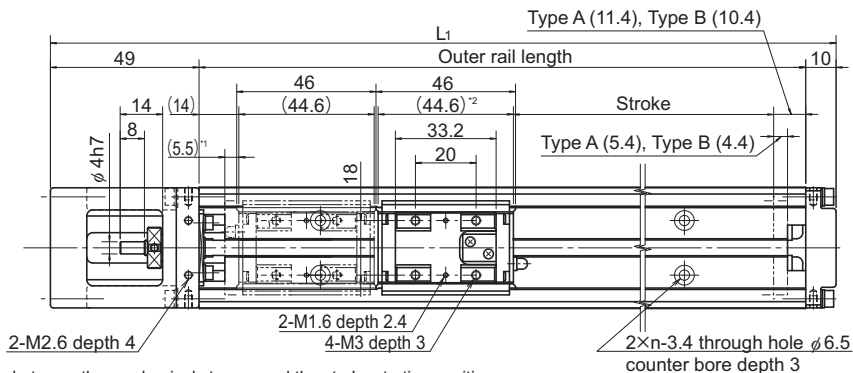

\*1 Distance between the mechanical stopper and the stroke starting position.

\*2 Indicates the inner block length when calculating the available stroke range. The length in model SKR-B (with two long-type inner blocks) is 90.6 mm.

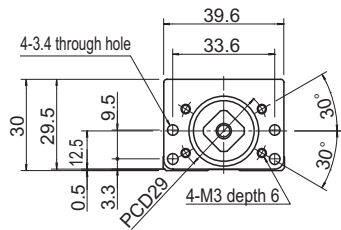
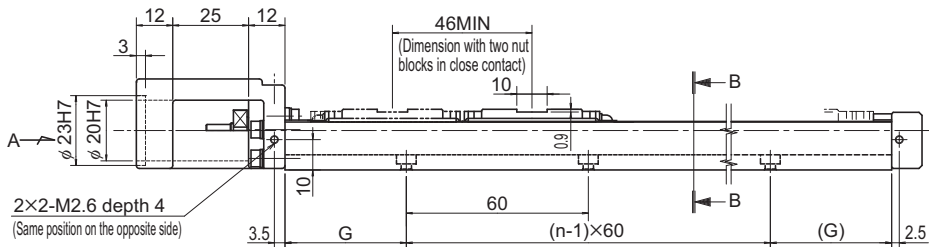

A arrow view

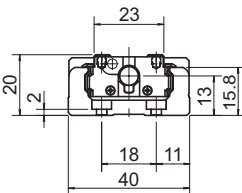

B-B cross section

Stroke (mm) (stroke between mechanical stoppers)		Outer rail length (mm)	Overall length L <sub>1</sub> (mm)	G (mm)	n	Overall main unit mass (kg)	
Type A	Type B <sup>*</sup>					Type A	Type B
30(40.9)	—	100	159	20	2	0.45	—
80(90.9)	35(44.9)	150	209	15	3	0.58	0.66
130(140.9)	85(94.9)	200	259	40	3	0.72	0.8

\*Indicates a value when two inner blocks are in close contact with each other.

## Model SKR20 (with a Cover)

Model SKR20□□A (with a Single Long Nut Block)

Model SKR20□□B (with Two Long Nut Blocks)

For model number coding, see **A2-28**.

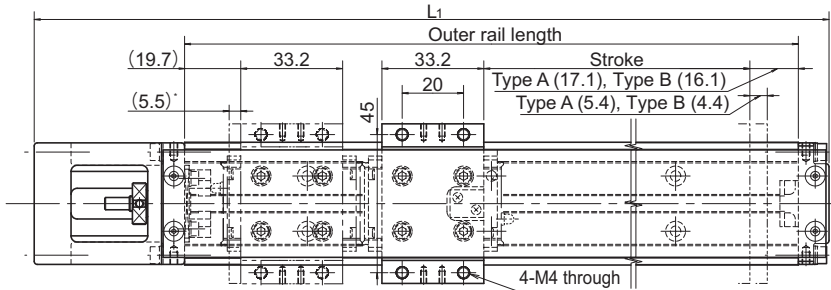

\* Distance between the mechanical stopper and the stroke starting position.

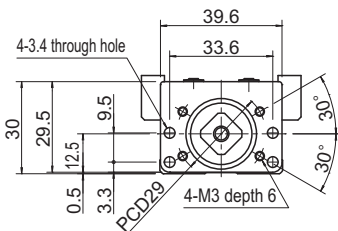
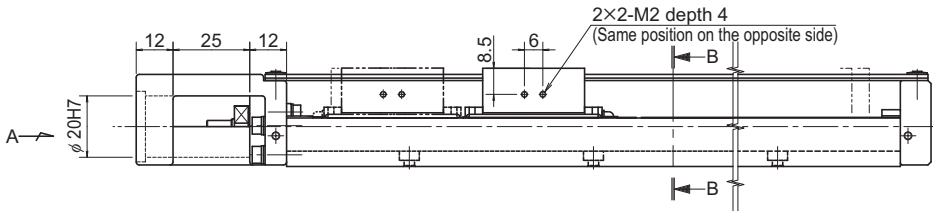

A arrow view

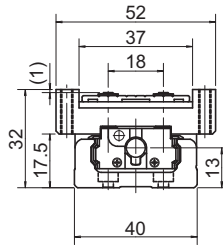

B-B cross section

Stroke (mm) (stroke between mechanical stoppers)		Outer rail length (mm)	Overall length L <sub>1</sub> (mm)	G (mm)	n	Overall main unit mass (kg)	
Type A	Type B					Type A	Type B
30(40.9)	—	100	159	20	2	0.5	—
80(90.9)	35(44.9)	150	209	15	3	0.64	0.76
130(140.9)	85(94.9)	200	259	40	3	0.79	0.91

\*Indicates a value when two inner blocks are in close contact with each other.

# Model SKR26 Standard Type

Model SKR26□□A (with a Single Long Nut Block)

Model SKR26□□B (with Two Long Nut Blocks)

For model number coding, see **A2-28**.

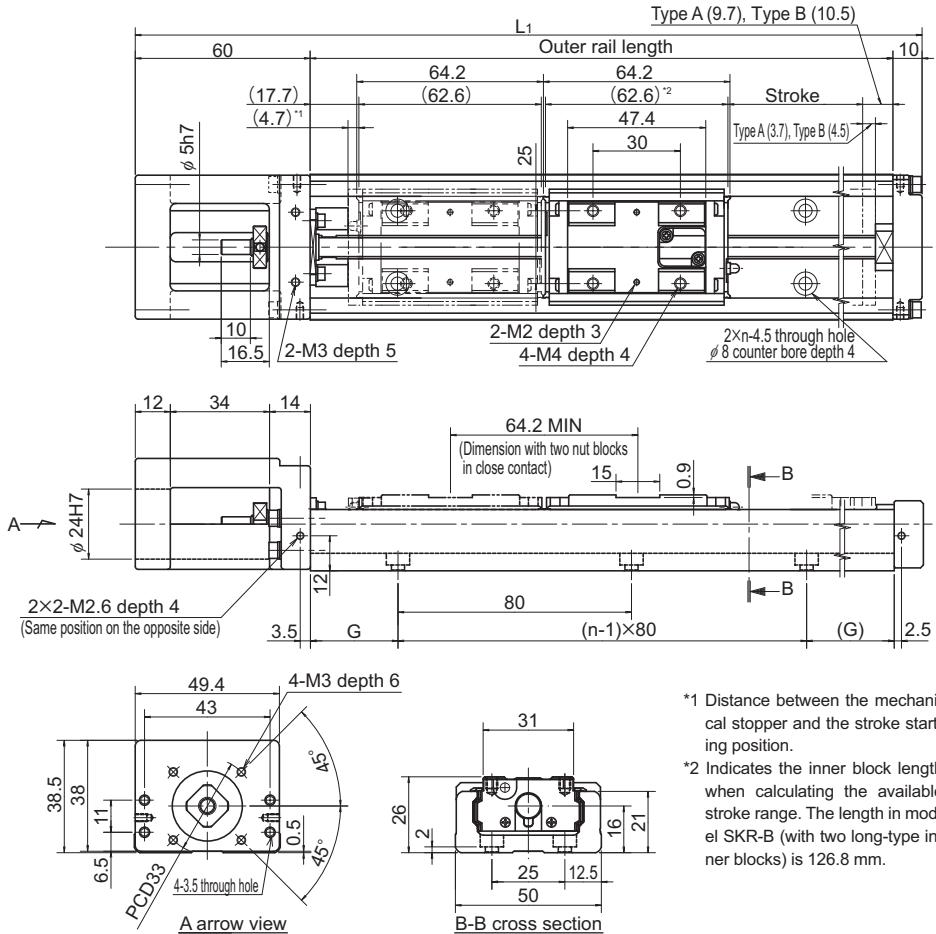

\*1 Distance between the mechanical stopper and the stroke starting position.

\*2 Indicates the inner block length when calculating the available stroke range. The length in model SKR-B (with two long-type inner blocks) is 126.8 mm.

Stroke (mm) (stroke between mechanical stoppers)		Outer rail length (mm)	Overall length L <sub>1</sub> (mm)	G (mm)	n	Overall main unit mass (kg)	
Type A	Type B <sup>*</sup>					Type A	Type B
60(68.4)	—	150	220	35	2	0.99	—
110(118.4)	45(54.2)	200	270	20	3	1.2	1.38
160(168.4)	95(104.2)	250	320	45	3	1.41	1.59
210(218.4)	145(154.2)	300	370	30	4	1.62	1.8

\*Indicates a value when two inner blocks are in close contact with each other.

## Model SKR26 (with a Cover)

Model SKR26□□A (with a Single Long Nut Block)

Model SKR26□□B (with Two Long Nut Blocks)

For model number coding, see **A2-28**.

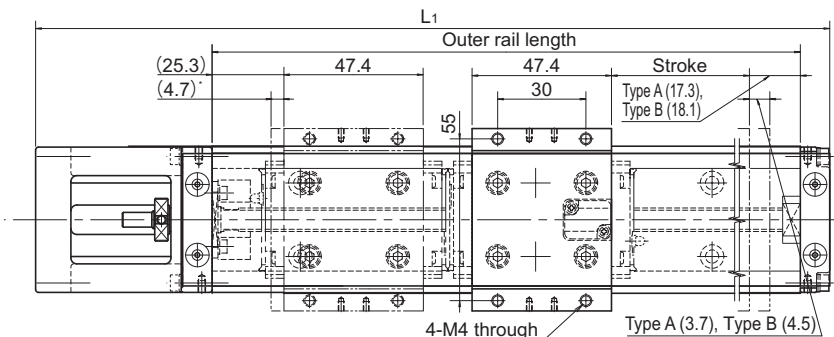

\* Distance between the mechanical stopper and the stroke starting position.

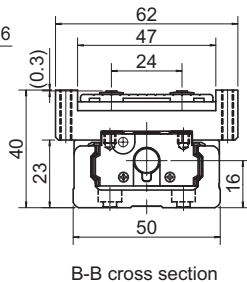
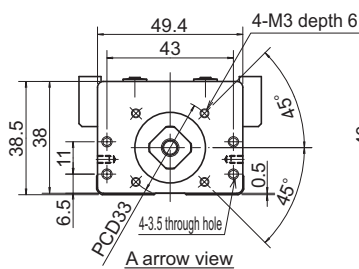
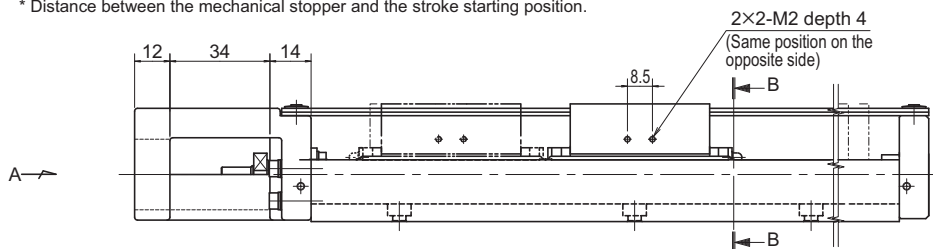

Stroke (mm) (stroke between mechanical stoppers)		Outer rail length (mm)	Overall length L <sub>1</sub> (mm)	G (mm)	n	Overall main unit mass (kg)	
Type A	Type B*					Type A	Type B
60(68.4)	—	150	220	35	2	1.1	—
110(118.4)	45(54.2)	200	270	20	3	1.32	1.57
160(168.4)	95(104.2)	250	320	45	3	1.54	1.79
210(218.4)	145(154.2)	300	370	30	4	1.76	2.01

\*Indicates a value when two inner blocks are in close contact with each other.

## Model SKR33 Standard Type

Model SKR33□□A (with a Single Long Nut Block)

Model SKR33□□B (with Two Long Nut Blocks)

For model number coding, see **A2-28**.

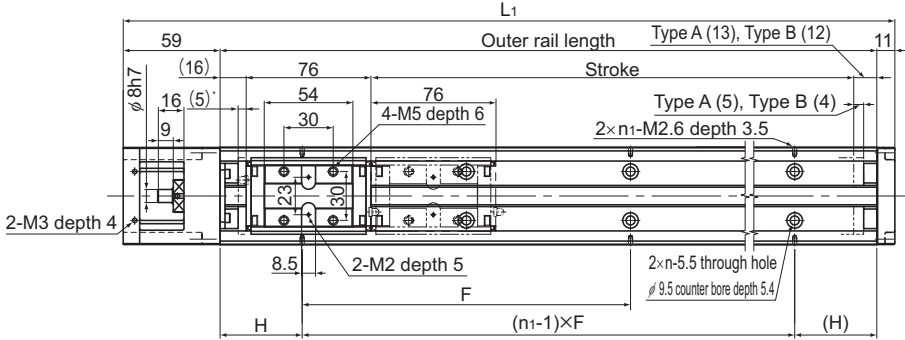

\* Distance between the mechanical stopper and the stroke starting position.

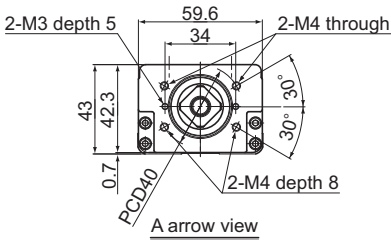
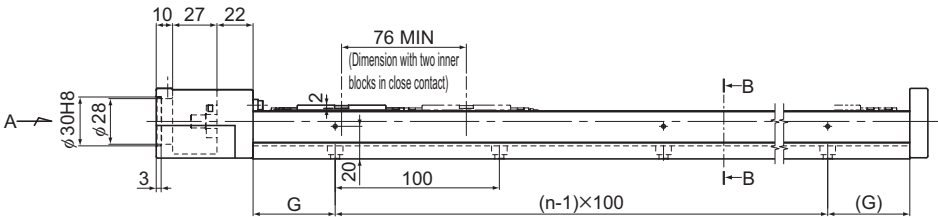

A arrow view

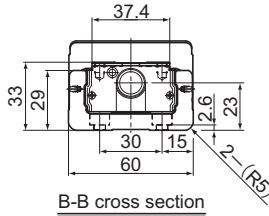

B-B cross section

Stroke (mm) (stroke between mechanical stoppers)		Outer rail length (mm)	Overall length L <sub>1</sub> (mm)	H (mm)	G (mm)	F (mm)	n	n <sub>1</sub>	Overall main unit mass (kg)	
Type A	Type B								Type A	Type B
45(55)	—	150	220	25	25	100	2	2	1.7	—
95(105)	—	200	270	50	50	100	2	2	2.1	—
195(205)	120(129)	300	370	50	50	200	3	2	2.8	3.1
295(305)	220(229)	400	470	100	50	200	4	2	3.5	3.8
395(405)	320(329)	500	570	50	50	200	5	3	4.2	4.5
495(505)	420(429)	600	670	100	50	200	6	3	5.0	5.3
595(605)	520(529)	700	770	50	50	200	7	4	5.7	6.0

\*Indicates a value when two inner blocks are in close contact with each other.

## Model SKR33 (with a Cover)

Model SKR33□□A (with a Single Long Nut Block)

Model SKR33□□B (with Two Long Nut Blocks)

For model number coding, see **A2-28**.

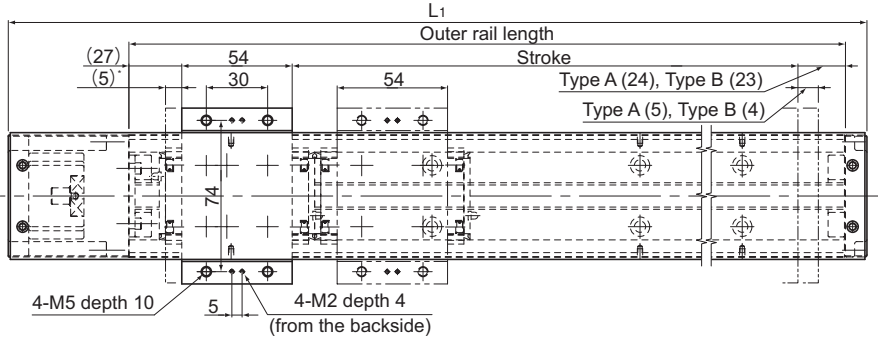

\* Distance between the mechanical stopper and the stroke starting position.

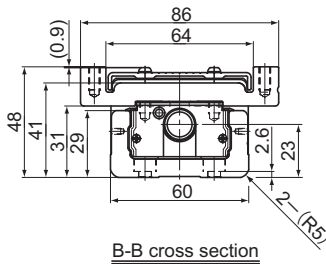
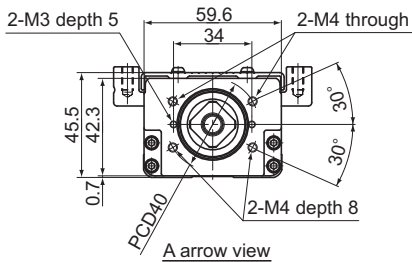
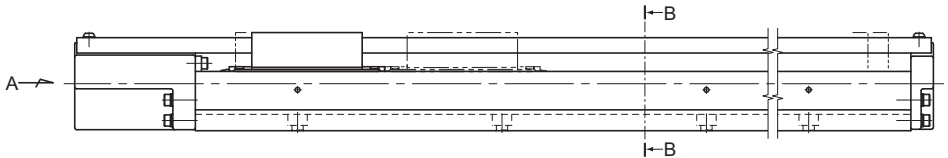

Stroke (mm) (stroke between mechanical stoppers)		Outer rail length (mm)	Overall length L(mm)	H (mm)	G (mm)	F (mm)	n	n <sub>1</sub>	Overall main unit mass (kg)	
Type A	Type B*								Type A	Type B
45(55)	—	150	220	25	25	100	2	2	1.9	—
95(105)	—	200	270	50	50	100	2	2	2.3	—
195(205)	120(129)	300	370	50	50	200	3	2	3.1	3.5
295(305)	220(229)	400	470	100	50	200	4	2	3.8	4.2
395(405)	320(329)	500	570	50	50	200	5	3	4.6	5.0
495(505)	420(429)	600	670	100	50	200	6	3	5.3	5.7
595(605)	520(529)	700	770	50	50	200	7	4	6.1	6.5

\*Indicates a value when two inner blocks are in close contact with each other.



# Model SKR33 Standard Type

Model SKR33□□C (with a Single Short Nut Block)

Model SKR33□□D (with Two Short Nut Blocks)

For model number coding, see **A2-28**.

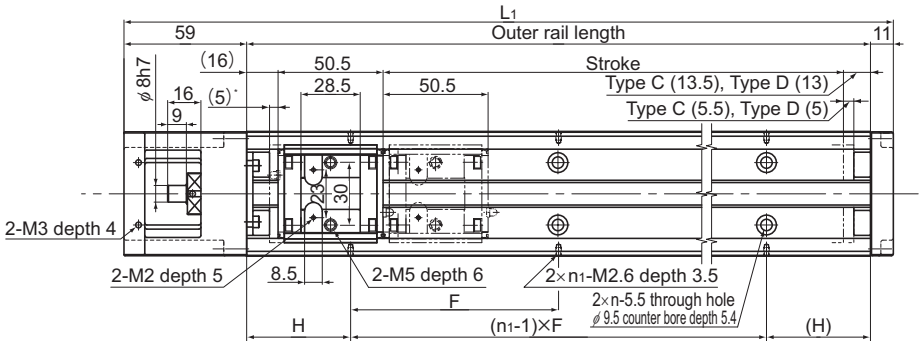

\* Distance between the mechanical stopper and the stroke starting position.

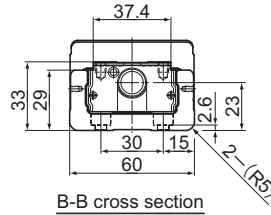
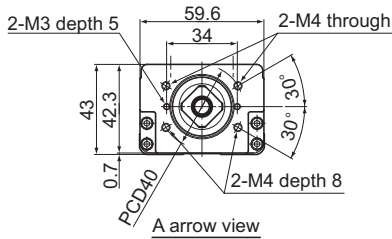
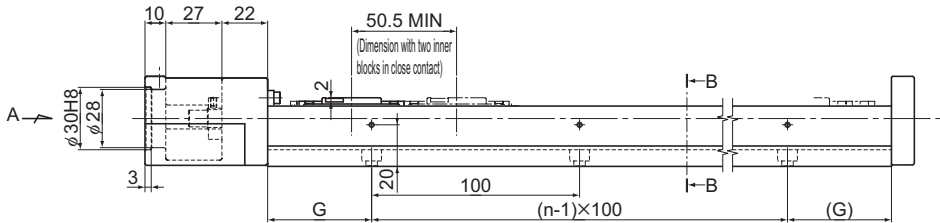

Stroke (mm) (stroke between mechanical stoppers)		Outer rail length (mm)	Overall length $L_1$ (mm)	H (mm)	G (mm)	F (mm)	n	$n_1$	Overall main unit mass (kg)	
Type C	Type D								Type C	Type D
70(80.5)	20(30)	150	220	25	25	100	2	2	1.6	1.8
120(130.5)	70(80)	200	270	50	50	100	2	2	2.0	2.1
220(230.5)	170(180)	300	370	50	50	200	3	2	2.7	2.8
320(330.5)	270(280)	400	470	100	50	200	4	2	3.4	3.6
420(430.5)	370(380)	500	570	50	50	200	5	3	4.1	4.3
520(530.5)	470(480)	600	670	100	50	200	6	3	4.8	5.0
620(630.5)	570(580)	700	770	50	50	200	7	4	5.5	5.7

\*Indicates a value when two inner blocks are in close contact with each other.

## Model SKR33 (with a Cover)

Model SKR33□□C (with a Single Short Nut Block)

Model SKR33□□D (with Two Short Nut Blocks)

For model number coding, see **A2-28**.

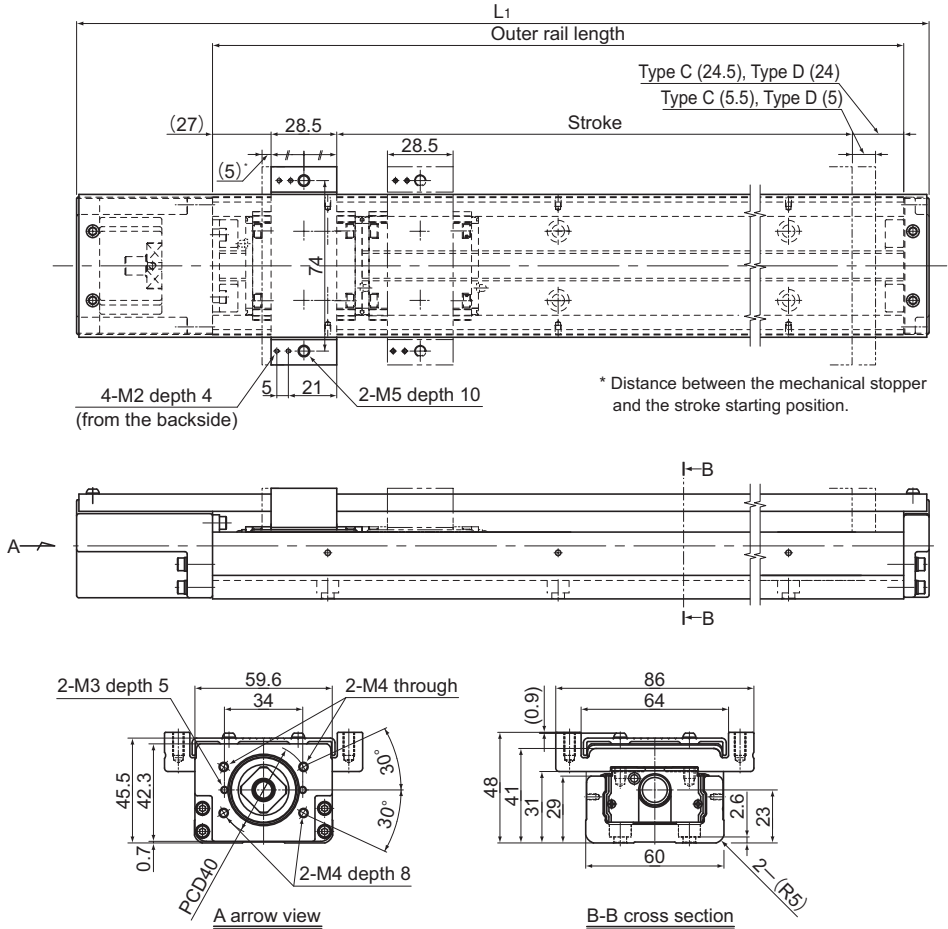

Stroke (mm) (stroke between mechanical stoppers)		Outer rail length (mm)	Overall length $L_1$ (mm)	H (mm)	G (mm)	F (mm)	n	$n_1$	Overall main unit mass (kg)	
Type C	Type D*								Type C	Type D
70(80.5)	20(30)	150	220	25	25	100	2	2	1.8	2.0
120(130.5)	70(80)	200	270	50	50	100	2	2	2.2	2.3
220(230.5)	170(180)	300	370	50	50	200	3	2	2.9	3.1
320(330.5)	270(280)	400	470	100	50	200	4	2	3.7	3.8
420(430.5)	370(380)	500	570	50	50	200	5	3	4.4	4.6
520(530.5)	470(480)	600	670	100	50	200	6	3	5.2	5.3
620(630.5)	570(580)	700	770	50	50	200	7	4	5.9	6.1

\*Indicates a value when two inner blocks are in close contact with each other.

# Model SKR46 Standard Type

Model SKR46□□A (with a Single Long Nut Block)

Model SKR46□□B (with Two Long Nut Blocks)

For model number coding, see **A2-28**.

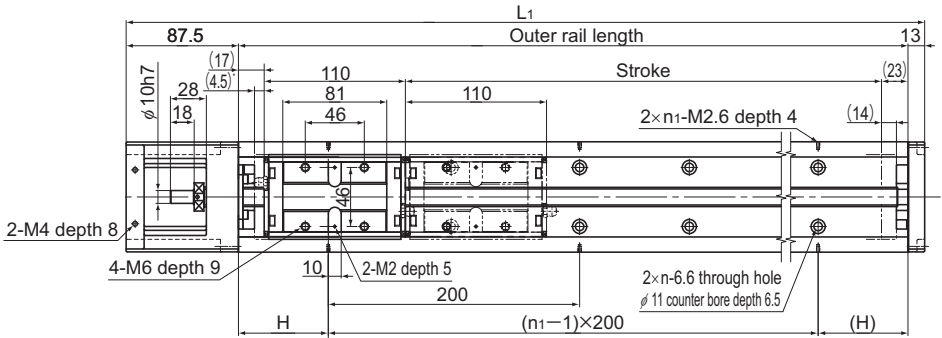

\* Distance between the mechanical stopper and the stroke starting position.

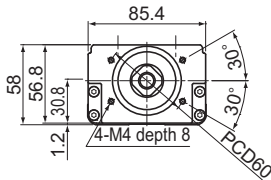
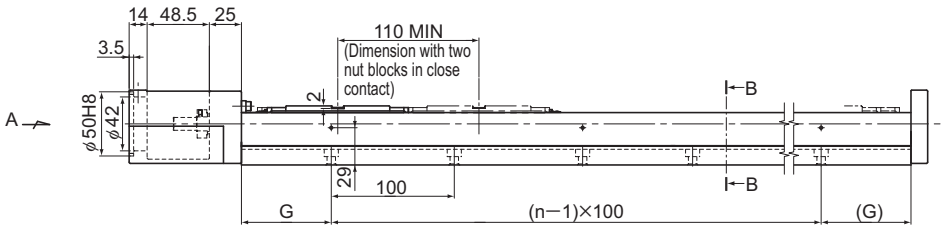

A arrow view

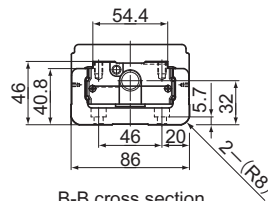

B-B cross section

Stroke (mm) (stroke between mechanical stoppers)		Outer rail length (mm)	Overall length $L_1$ (mm)	H (mm)	G (mm)	n	$n_1$	Overall main unit mass (kg)	
Type A	Type B							Type A	Type B
190(208.5)	80(98.5)	340	440.5	70	70	3	2	6.4	7.4
290(308.5)	180(198.5)	440	540.5	20	70	4	3	7.8	8.7
390(408.5)	280(298.5)	540	640.5	70	70	5	3	9.2	10.1
490(508.5)	380(398.5)	640	740.5	20	70	6	4	10.6	11.5
590(608.5)	480(498.5)	740	840.5	70	70	7	4	12.0	12.9
690(708.5)	580(598.5)	840	940.5	20	70	8	5	13.4	14.4
790(808.5)	680(698.5)	940	1040.5	70	70	9	5	14.8	15.7

\*Indicates a value when two inner blocks are in close contact with each other.

## Model SKR46 (with a Cover)

Model SKR46□□A (with a Single Long Nut Block)

Model SKR46□□B (with Two Long Nut Blocks)

For model number coding, see **A2-28**.

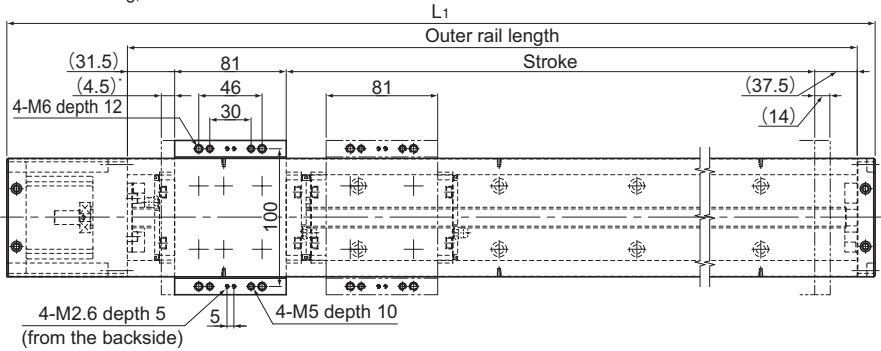

\* Distance between the mechanical stopper and the stroke starting position.

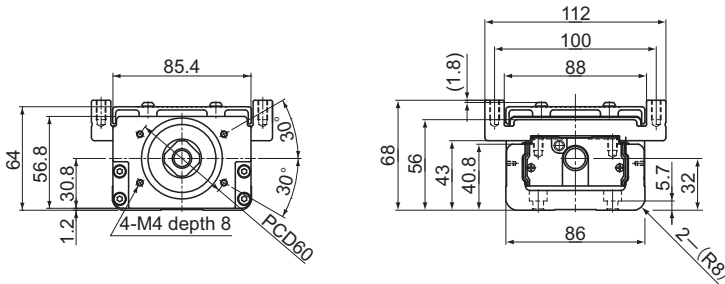
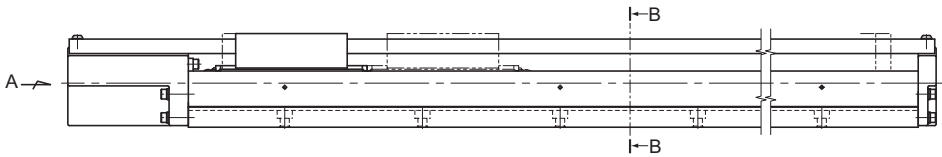

A arrow view

B-B cross section

Stroke (mm) (stroke between mechanical stoppers)		Outer rail length (mm)	Overall length $L_1$ (mm)	H (mm)	G (mm)	n	$n_1$	Overall main unit mass (kg)	
Type A	Type B*							Type A	Type B
190(208.5)	80(98.5)	340	440.5	70	70	3	2	7.1	8.3
290(308.5)	180(198.5)	440	540.5	20	70	4	3	8.6	9.8
390(408.5)	280(298.5)	540	640.5	70	70	5	3	10.0	11.3
490(508.5)	380(398.5)	640	740.5	20	70	6	4	11.5	12.7
590(608.5)	480(498.5)	740	840.5	70	70	7	4	13.0	14.2
690(708.5)	580(598.5)	840	940.5	20	70	8	5	14.5	15.7
790(808.5)	680(698.5)	940	1040.5	70	70	9	5	16.0	17.2

\*Indicates a value when two inner blocks are in close contact with each other.

# Model SKR46 Standard Type

Model SKR46□□C (with a Single Short Nut Block)

Model SKR46□□D (with Two Short Nut Blocks)

For model number coding, see **A2-28**.

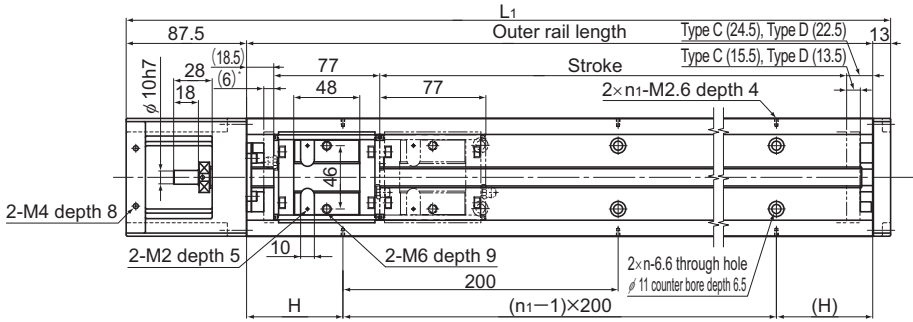

\* Distance between the mechanical stopper and the stroke starting position.

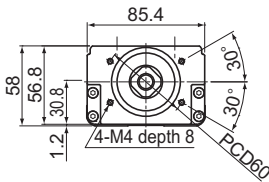
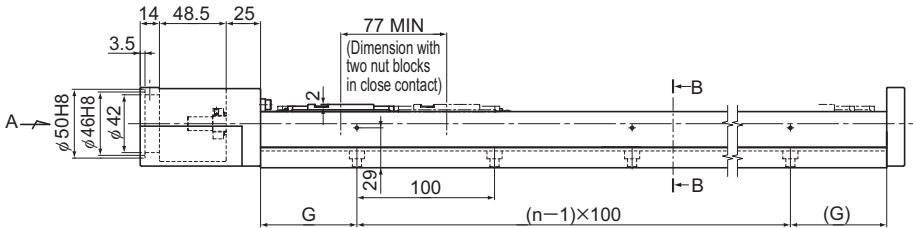

A arrow view

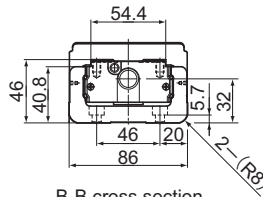

B-B cross section

Stroke (mm) (stroke between mechanical stoppers)		Outer rail length (mm)	Overall length L <sub>1</sub> (mm)	H (mm)	G (mm)	n	n <sub>1</sub>	Overall main unit mass (kg)	
Type C	Type D							Type C	Type D
220(241.5)	145(164.5)	340	440.5	70	70	3	2	6.1	6.7
320(341.5)	245(264.5)	440	540.5	20	70	4	3	7.5	8.1
420(441.5)	345(364.5)	540	640.5	70	70	5	3	8.9	9.5
520(541.5)	445(464.5)	640	740.5	20	70	6	4	10.3	10.8
620(641.5)	545(564.5)	740	840.5	70	70	7	4	11.7	12.2
720(741.5)	645(664.5)	840	940.5	20	70	8	5	13.1	13.7
820(841.5)	745(764.5)	940	1040.5	70	70	9	5	14.5	15.0

\*Indicates a value when two inner blocks are in close contact with each other.

## Model SKR46 (with a Cover)

Model SKR46□□C (with a Single Short Nut Block)

Model SKR46□□D (with Two Short Nut Blocks)

For model number coding, see **A2-28**.

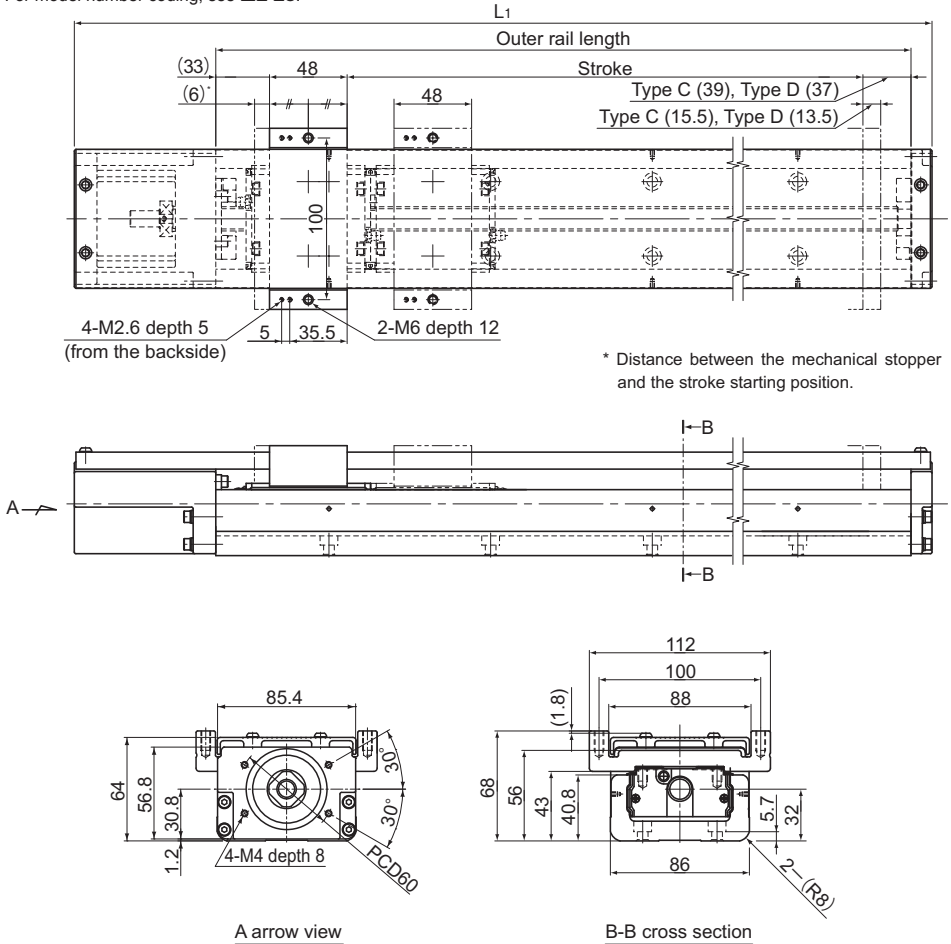

Stroke (mm) (stroke between mechanical stoppers)		Outer rail length (mm)	Overall length L <sub>1</sub> (mm)	H (mm)	G (mm)	n	n <sub>1</sub>	Overall main unit mass (kg)	
Type C	Type D*							Type C	Type D
220(241.5)	145(164.5)	340	440.5	70	70	3	2	6.6	7.4
320(341.5)	245(264.5)	440	540.5	20	70	4	3	8.1	8.9
420(441.5)	345(364.5)	540	640.5	70	70	5	3	9.6	10.3
520(541.5)	445(464.5)	640	740.5	20	70	6	4	11.0	11.8
620(641.5)	545(564.5)	740	840.5	70	70	7	4	12.5	13.3
720(741.5)	645(664.5)	840	940.5	20	70	8	5	14	14.8
820(841.5)	745(764.5)	940	1040.5	70	70	9	5	15.5	16.3

\*Indicates a value when two inner blocks are in close contact with each other.

# Model SKR55 Standard Type

Model SKR55□□A (with a Single Long Nut Block)

Model SKR55□□B (with Two Long Nut Blocks)

For model number coding, see **A2-28**.

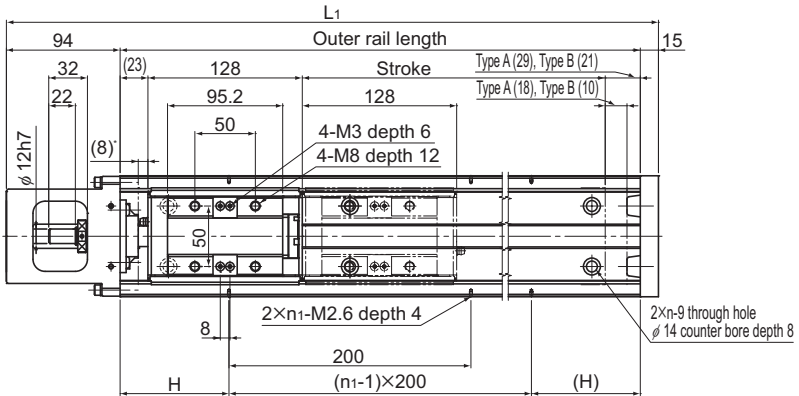

\* Distance between the mechanical stopper and the stroke starting position.

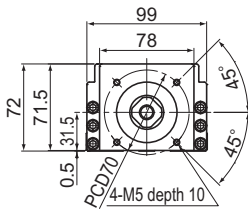
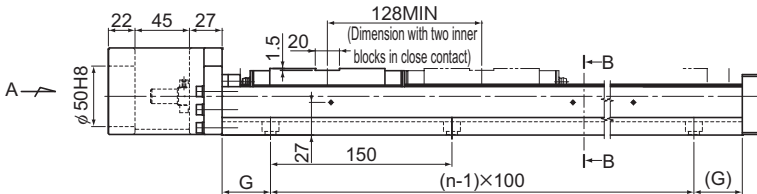

A arrow view

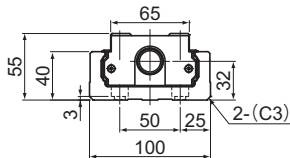

B-B cross section

Stroke (mm) (stroke between mechanical stoppers)		Outer rail length (mm)	Overall length $L_1$ (mm)	H (mm)	G (mm)	n	$n_1$	Overall main unit mass (kg)	
Type A	Type B*							Type A	Type B
800 (826)	680 (698)	980	1089	90	40	7	5	20.8	22.7
900 (926)	780 (798)	1080	1189	40	15	8	6	22.6	24.5
1000 (1026)	880 (898)	1180	1289	90	65	8	6	24.4	26.3
1100 (1126)	980 (998)	1280	1389	40	40	9	7	26.1	28
1200 (1226)	1080 (1098)	1380	1489	90	15	10	7	27.9	29.8

\*Indicates a value when two inner blocks are in close contact with each other.

## Model SKR55 (with a Cover)

Model SKR55□□A (with a Single Long Nut Block)

Model SKR55□□B (with Two Long Nut Blocks)

For model number coding, see **A2-28**.

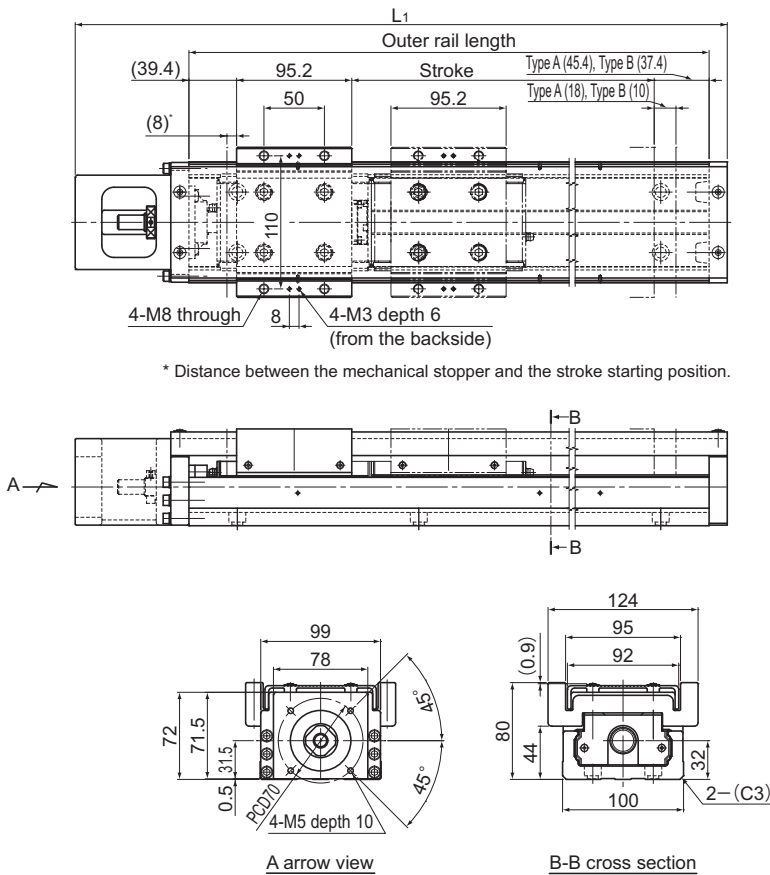

Stroke (mm) (stroke between mechanical stoppers)		Outer rail length (mm)	Overall length L <sub>1</sub> (mm)	Overall main unit mass (kg)	
Type A	Type B*			Type A	Type B
800 (826)	680 (698)	980	1089	23.8	27.6
900 (926)	780 (798)	1080	1189	25.7	29.5
1000 (1026)	880 (898)	1180	1289	27.6	31.4
1100 (1126)	980 (998)	1280	1389	29.5	33.3
1200 (1226)	1080 (1098)	1380	1489	31.4	35.2

\*Indicates a value when two inner blocks are in close contact with each other.



# Model SKR65 Standard Type

Model SKR65□□A (with a Single Long Nut Block)

Model SKR65□□B (with Two Long Nut Blocks)

For model number coding, see **A2-28**.

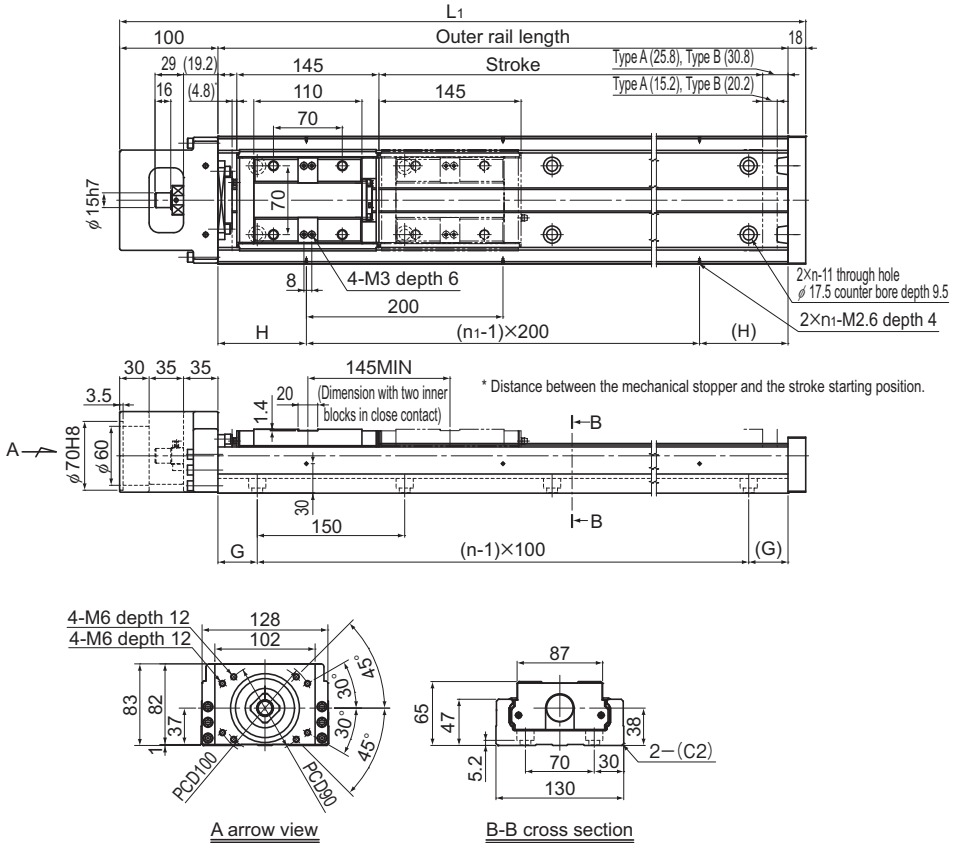

Stroke (mm) (stroke between mechanical stoppers)		Outer rail length (mm)	Overall length $L_1$ (mm)	H (mm)	G (mm)	n	$n_1$	Overall main unit mass (kg)	
Type A	Type B*							Type A	Type B
790 (810)	640 (665)	980	1098	90	40	7	5	30.2	33.2
990 (1010)	840 (865)	1180	1298	90	65	8	6	35.4	38.4
1190 (1210)	1040 (1065)	1380	1498	90	90	9	7	40.6	43.6
1490 (1510)	1340 (1365)	1680	1798	40	90	11	9	48.3	51.3

\*Indicates a value when two inner blocks are in close contact with each other.

## Model SKR65 (with a Cover)

Model SKR65□□A (with a Single Long Nut Block)

Model SKR65□□B (with Two Long Nut Blocks)

For model number coding, see **A2-28**.

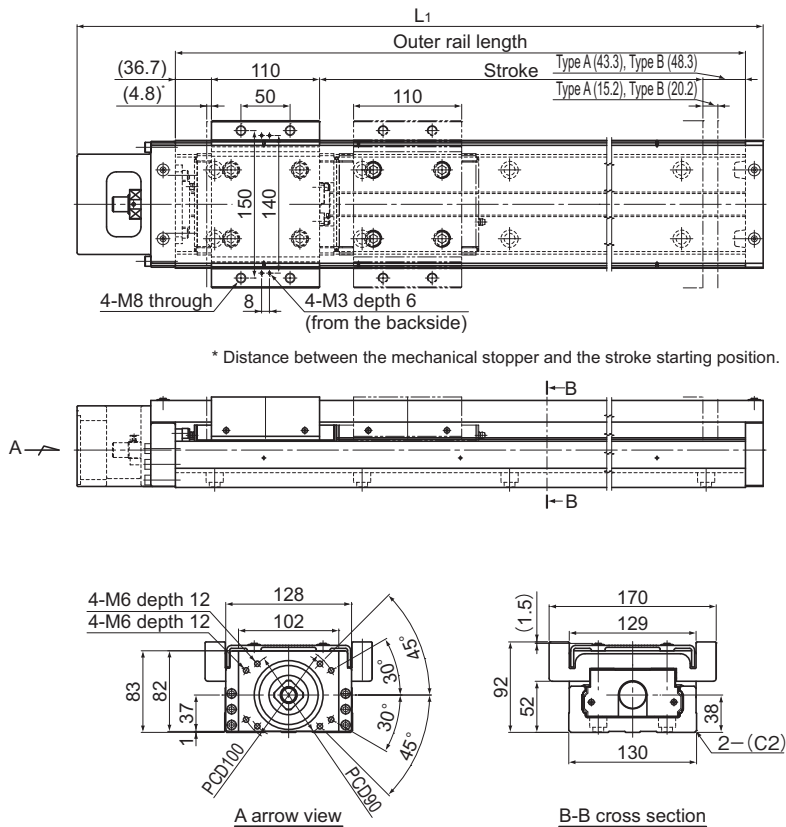

Stroke (mm) (stroke between mechanical stoppers)		Outer rail length (mm)	Overall length L <sub>1</sub> (mm)	Overall main unit mass (kg)	
Type A	Type B*			Type A	Type B
790 (810)	640 (665)	980	1098	33.4	40.1
990 (1010)	840 (865)	1180	1298	38.9	45.6
1190 (1210)	1040 (1065)	1380	1498	44.3	51
1490 (1510)	1340 (1365)	1680	1798	52.4	59.1

\*Indicates a value when two inner blocks are in close contact with each other.

## Mass of Moving Element

Table14 shows the mass of the inner block and top table of model SKR.

Table14 Mass of the Inner Block and Top table of SKR

Unit: kg

Model No.	Long nut block types (A)		Short nut block types (C)	
	Inner block	Top table	Inner block	Top table
SKR20	0.064	0.038	—	—
SKR26	0.153	0.074	—	—
SKR33	0.31	0.13	0.17	0.07
SKR46	0.91	0.34	0.57	0.20
SKR55	1.9	1.9	—	—
SKR65	3.0	3.5	—	—

## Bellows

For model SKR, bellows are available for contamination protection in addition to a cover.

[Model SKR-A (with a Single Long Nut Block)]

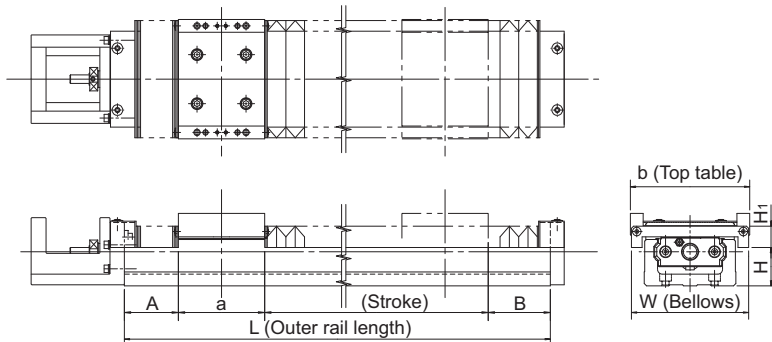

Unit: mm

Model No.	Stroke <sup>*1</sup>	Outer rail length L	A	B	a	b	W	H	H <sub>1</sub>
SKR20	20(30.8)	100	18.8	17.2	33.2	52	60	10	20
	55(67.8)	150	25.3	23.7					
	80(93.6)	200	37	36.2					
SKR26	50(60.7)	150	23.7	17.6	47.4	62	74	18	20
	80(91.6)	200	32.8	28.2					
	110(125.6)	250	40.8	36.2					
	160(175.6)	300	40.8	36.2					
SKR33	30(42.8)	150	25.6	27.6	54	86	84	24.5	20
	60(72.8)	200	35.6	37.6					
	140(152.8)	300	45.6	47.6					
	210(222.8)	400	60.6	62.6					
	290(302.8)	500	70.6	72.6					
	360(372.8)	600	85.6	87.6					
SKR46	140(155.8)	340	52.1	51.1	81	112	110	36	20
	210(225.8)	440	67.1	66.1					
	290(305.8)	540	77.1	76.1					
	360(375.8)	640	92.1	91.1					
	440(455.8)	740	102.1	101.1					
	510(525.8)	840	117.1	116.1					
590(605.8)	940	127.1	126.1						

\*1 The value in the parentheses represents the maximum stroke.

Unit: mm

Model No.	Stroke <sup>*1</sup>	Outer rail length L	A	B	a	b	W	H	H <sub>1</sub>
SKR55 <sup>*2</sup>	700 (719.6)	980	84.6	80.6	95.2	124	154	37	40
	790 (809.6)	1080	89.6	85.6					
	870 (889.6)	1180	99.6	95.6					
	960 (979.6)	1280	104.6	100.6					
	1050 (1069.6)	1380	109.6	105.6					
SKR65 <sup>*2</sup>	680 (703.2)	980	85.1	81.7	110	170	184	40	47
	860 (883.2)	1180	95.1	91.7					
	1030 (1053.2)	1380	110.1	106.7					
	1290 (1313.2)	1680	130.1	126.7					

\*1 The value in the parentheses represents the maximum stroke.

\*2 The bellows for models SKR55 and SKR65 are only suitable for horizontal orientation. If the bellows is to be used in other orientations (vertical or wall-mounted), contact THK.

## [Model SKR-B (with Two Long Nut Blocks)]

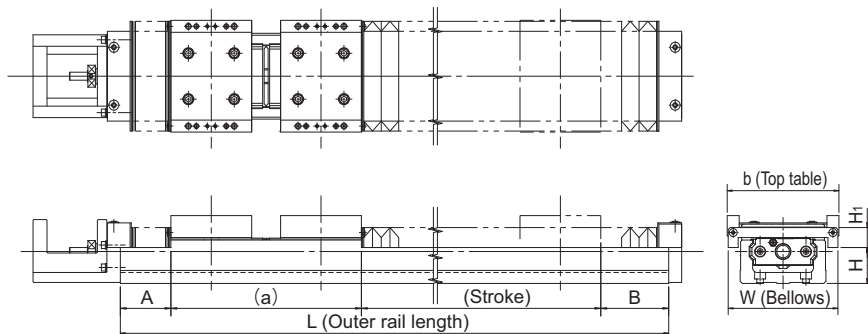

Unit: mm

Model No.	Stroke <sup>*1,2</sup>	Outer rail length L	A	B	a	b	W	H	H <sub>1</sub>																																																																																																																				
SKR20	25(34.8)	150	18.8	17.2	79.2	52	60	10	20																																																																																																																				
	60(71.8)	200	25.3	23.7						SKR26	35(46.5)	200	23.7	17.6	111.6	62	74	18	20	65(77.4)	250	32.8	28.2	115(127.4)	300	32.8	28.2	SKR33	80(96.8)	300	35.6	37.6	130	86	84	24.5	20	150(166.8)	400	50.6	52.6	230(246.8)	500	60.6	62.6	300(316.8)	600	75.6	77.6	SKR46	60(75.8)	340	37.1	36.1	191	112	110	36	20	130(145.8)	440	52.1	51.1	210(225.8)	540	62.1	61.1	280(295.8)	640	77.1	76.1	360(375.8)	740	87.1	86.1	430(445.8)	840	102.1	101.1	510(525.8)	940	112.1	111.1	SKR55 <sup>*3</sup>	590(612)	980	74.6	70.6	222.8	124	154	37	40	670(692)	1080	84.6	80.6	760(782)	1180	89.6	85.6	850(872)	1280	94.6	90.6	930(952)	1380	104.6	100.6	SKR65 <sup>*3</sup>	550(578.6)	980	75.1	71.7	254.6	170	184	40	47	720(748.6)	1180	90.1	86.7	900(928.6)	1380
SKR26	35(46.5)	200	23.7	17.6	111.6	62	74	18	20																																																																																																																				
	65(77.4)	250	32.8	28.2																																																																																																																									
	115(127.4)	300	32.8	28.2																																																																																																																									
SKR33	80(96.8)	300	35.6	37.6	130	86	84	24.5	20																																																																																																																				
	150(166.8)	400	50.6	52.6																																																																																																																									
	230(246.8)	500	60.6	62.6																																																																																																																									
	300(316.8)	600	75.6	77.6																																																																																																																									
SKR46	60(75.8)	340	37.1	36.1	191	112	110	36	20																																																																																																																				
	130(145.8)	440	52.1	51.1																																																																																																																									
	210(225.8)	540	62.1	61.1																																																																																																																									
	280(295.8)	640	77.1	76.1																																																																																																																									
	360(375.8)	740	87.1	86.1																																																																																																																									
	430(445.8)	840	102.1	101.1																																																																																																																									
	510(525.8)	940	112.1	111.1																																																																																																																									
SKR55 <sup>*3</sup>	590(612)	980	74.6	70.6	222.8	124	154	37	40																																																																																																																				
	670(692)	1080	84.6	80.6																																																																																																																									
	760(782)	1180	89.6	85.6																																																																																																																									
	850(872)	1280	94.6	90.6																																																																																																																									
	930(952)	1380	104.6	100.6																																																																																																																									
SKR65 <sup>*3</sup>	550(578.6)	980	75.1	71.7	254.6	170	184	40	47																																																																																																																				
	720(748.6)	1180	90.1	86.7																																																																																																																									
	900(928.6)	1380	100.1	96.7																																																																																																																									
	1160(1188.6)	1680	120.1	116.7																																																																																																																									

\*1 The strokes in the table are values when the blocks are in close contact with each other.

\*2 The value in the parentheses represents the maximum stroke.

\*3 The bellows for models SKR55 and SKR65 are only suitable for horizontal orientation. If the bellows is to be used in other orientations (vertical or wall-mounted), contact THK.

Note) The bellows cannot be attached between the top tables.

### [Model SKR-C (with a Single Short Nut Block)]

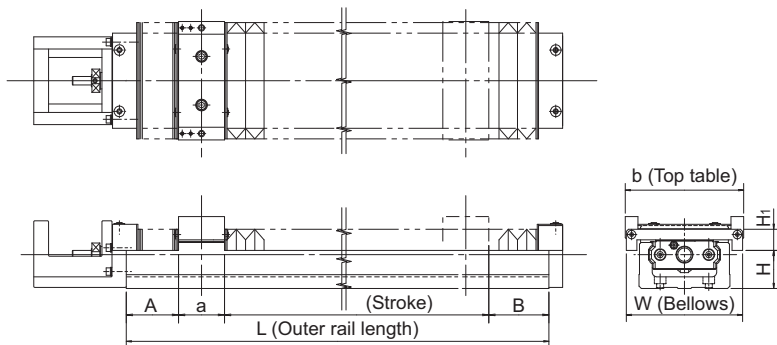

Unit: mm

Model No.	Stroke*	Outer rail length L	A	B	a	b	W	H	H <sub>1</sub>
SKR33	45(58.3)	150	30.6	32.6	28.5	80	80	21.5	17.5
	85(98.3)	200	35.6	37.6					
	155(168.3)	300	50.6	52.6					
	235(248.3)	400	60.6	62.6					
	385(398.3)	600	85.6	87.6					
SKR46	160(178.8)	340	57.1	56.1	48	112	110	36	20
	230(248.8)	440	72.1	71.1					
	310(328.8)	540	82.1	81.1					
	380(398.8)	640	97.1	96.1					
	460(478.8)	740	107.1	106.1					
	530(548.8)	840	122.1	121.1					
610(628.8)	940	132.1	131.1						

\*The value in the parentheses represents the maximum stroke.

## [Model SKR-D (with Two Short Nut Blocks)]

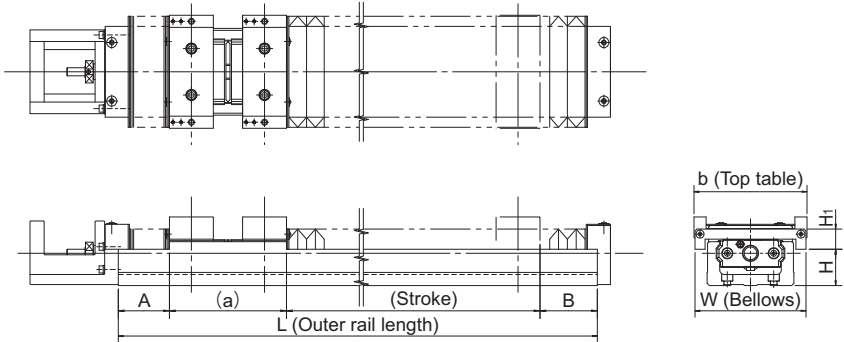

Unit: mm

Model No.	Stroke <sup>*1,2</sup>	Outer rail length L	A	B	a	b	W	H	H <sub>1</sub>
SKR33	45(57.8)	200	30.6	32.6	79	86	84	24.5	20
	125(137.8)	300	40.6	42.6					
	195(207.8)	400	55.6	57.6					
	275(287.8)	500	65.6	67.6					
	345(357.8)	600	80.6	82.6					
SKR46	110(121.8)	340	47.1	46.1	125	112	110	36	20
	180(191.8)	440	62.1	61.1					
	260(271.8)	540	72.1	71.1					
	330(341.8)	640	87.1	86.1					
	410(421.8)	740	97.1	96.1					
	480(491.8)	840	112.1	111.1					
	560(571.8)	940	122.1	121.1					

\*1 The strokes in the table are values when the blocks are in close contact with each other.

\*2 The value in the parentheses represents the maximum stroke.

Note) The bellows cannot be attached between the top tables.



# Sensor

Optional photo sensors and proximity sensors are available for SKR models.

## [Example of Installation]

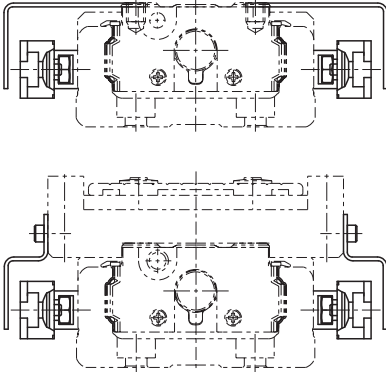

Table15 With/without a sensor

Symbol	Description	Type	Accessory <sup>*1</sup>
0	None	—	—
1	With sensor rail	—	Mounting screws, sensor rail
2	Photo Sensor <sup>*2</sup> [3 units]	EE-SX671 (Omron Corp.)	Mounting screw/nut, detecting plate, sensor rail, mounting plate, connector (EE-1001)
6	Photo Sensor <sup>*2</sup> [3 units]	EE-SX674 (Omron Corp.)	Mounting screw/nut, detecting plate, sensor rail, mounting plate, connector (EE-1001)
7	Proximity Sensor N.O. contact [3 units]	APM-D3A1-001 (Azbil Corp.)	Mounting screw/nut, detecting plate, sensor rail
B	Proximity Sensor N.C. contact [3 units]	APM-D3B1-003 (Azbil Corp.)	Mounting screw/nut, detecting plate, sensor rail
E	Proximity Sensor N.O. contact [1 unit] N.C. contact [2 units]	APM-D3A1-001 (Azbil Corp.)	Mounting screw/nut, detecting plate, sensor rail
H	Proximity Sensor N.O. contact [3 units]	GX-F12A (Panasonic Industrial Devices SUNX Co., Ltd.)	Mounting screw/nut, detecting plate, sensor rail
L	Proximity Sensor N.C. contact [3 units]	GX-F12B (Panasonic Industrial Devices SUNX Co., Ltd.)	Mounting screw/nut, detecting plate, sensor rail
J	Proximity Sensor N.O. contact [1 unit] N.C. contact [2 units]	GX-F12A (Panasonic Industrial Devices SUNX Co., Ltd.) GX-F12B	Mounting screw/nut, detecting plate, sensor rail
M	Proximity Sensor N.O. contact [1 unit] N.C. contact [2 units]	GX-F12A-P (Panasonic Industrial Devices SUNX Co., Ltd.) GX-F12B-P	Mounting screw/nut, detecting plate, sensor rail

N.O. contact: normally open contact

N.C. contact: normally closed contact

\*1 If the stroke is less than 70 mm, 2 sensor flags and 2 sensor rails will be included. SKR20 and 26 ship with the sensor rail already installed.

\*2 The photo-sensors can be switched between ON when lit and ON when unlit.

### [Proximity Sensor]

APM-D3A1-001 (Azbil Corp.) 3 units

APM-D3B1-003 (Azbil Corp.) 3 units

GX-F12A (Panasonic Industrial Devices SUNX Co., Ltd.) 3 units

GX-F12B (Panasonic Industrial Devices SUNX Co., Ltd.) 3 units

GX-F12A-P (Panasonic Industrial Devices SUNX Co., Ltd.) 3 units

GX-F12B-P (Panasonic Industrial Devices SUNX Co., Ltd.) 3 units

#### ● Proximity Sensor: APM-D3A1-001 APM-D3B1-003 (Azbil Corp.)

Unit: mm

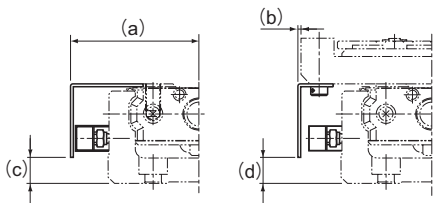

Model No.	a	b	c	d
SKR20	32.5	6.6	6	6
SKR26	37.5	6.4	8	8
SKR33	43	0.3	14.8	15
SKR46	56.2	0.2	26.8	22
SKR55	62.4	0.4	22	22
SKR65	77.4	-7.6	25.1	25

#### ● Proximity sensor GX-F12A GX-F12B GX-F12A-P GX-F12B-P (Panasonic Industrial Devices SUNX Co., Ltd.)

Unit: mm

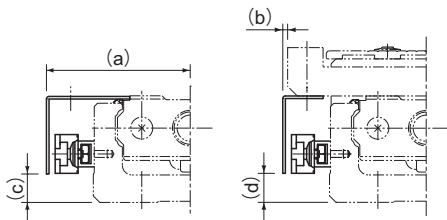

Model No.	a	b	c	d
SKR20	34	8.1	3.6	4
SKR26	39	7.9	6	6
SKR33	44.7	2	13.8	15
SKR46	57.7	1.8	24.8	22
SKR55	64.5	2.5	22	22
SKR65	79	-6	25.1	25

#### ● Proximity Sensor (with Bellows)

Unit: mm

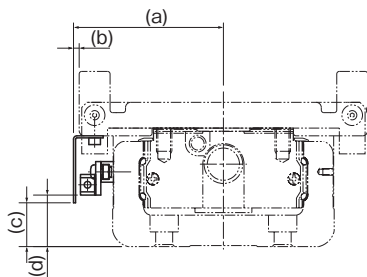

Model No.	a	b	c	d	Sensor type
SKR33	47	4	8	6	GX-F12 (Panasonic Industrial Devices SUNX Co., Ltd.)
SKR46	59.8	3.8	15	15	
SKR33	45.3	2.3	10	11	APM-D3 (Azbil Corp.)
SKR46	56.2	0.2	22	25	

**[Photo Sensor]**

EE-SX671 (Omron Corp.) 3 units

EE-SX674 (Omron Corp.) 3 units

Connector EE-1001 (Omron Corp.) 3 units

Note) The connector is an appended article.

● **Photo Sensor: EE-SX671 (Omron Corp.)**

Unit: mm

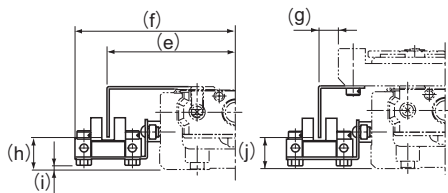

Model No.	e	f	g	h	i	j
SKR20	41	53.8	15	9.4	0.9	9.5
SKR26	45.9	58.7	14.9	11.4	2.9	11.5
SKR33	51.1	63.6	8.3	18.8	7.4	19.5
SKR46	64.1	76.6	8.3	29.8	16.4	26.5
SKR55	70.7	83.5	8.6	24.5	13.6	25
SKR65	85.5	98.5	0.6	28.1	16.6	28

● **Photo Sensor: EE-SX674 (Omron Corp.)**

Unit: mm

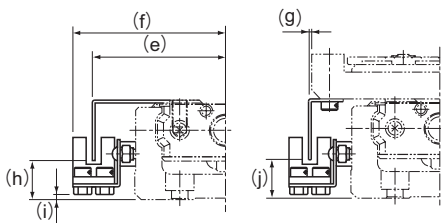

Model No.	e	f	g	h	i	j
SKR20	38.3	44.8	12.5	10.9	0.6	11
SKR26	43.3	49.7	12.5	12.9	2.6	13
SKR33	45.9	52.1	3.3	17.8	7.1	20
SKR46	58.9	65.1	3.2	28.8	16.1	27
SKR55	63.5	70.5	1.5	24.5	13.1	24
SKR65	79	85.5	-6	28.6	16.1	28

● **Photo Sensor (with Bellows)**

Unit: mm

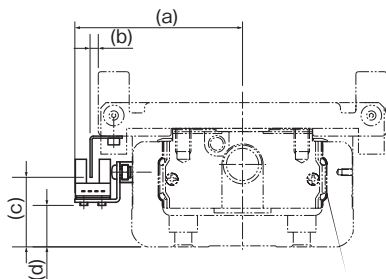

Model No.	a	b	c	d	Sensor type
SKR33	63.6	8.3	19.5	7.4	EE-SX671 (Omron Corp.)
SKR46	76.6	8.3	26.5	16.4	
SKR33	52.1	3.3	18	5.1	EE-SX674 (Omron Corp.)
SKR46	65.1	3.2	27	16.1	

**[Sensor Rail]**

The sensor rail can be attached alone.

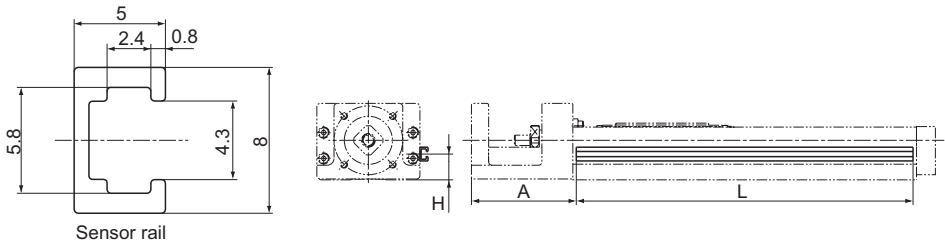

Sensor rail

Unit: mm

Model No.	Stroke*	Outer rail length	H	A	L
SKR20	30	100	10	43	111
	80	150			161
	130	200			211
SKR26	60	150	12	54	161
	110	200			211
	160	250			261
	210	300			311
SKR33	45	150	20	61	146
	95	200			196
	195	300			296
	295	400			396
	395	500			496
	495	600			596
	595	700			696
SKR46	190	340	29	89.5	336
	290	440			436
	390	540			536
	490	640			636
	590	740			736
	690	840			836
SKR55	790	940	27	96	936
	800	980			976
	900	1080			1076
	1000	1180			1176
	1100	1280			1276
SKR65	1200	1380	30	102	1376
	790	980			976
	990	1180			1176
	1190	1380			1376
	1490	1680			1676

\*Indicates stroke length when one long-type inner block is incorporated.

## Housing

THK also offers Housing A provided with a separate motor, and a turnaround type of Housing A, as options in order to support a motor bracket or a turnaround section that the customer may separately produce.

### [Housing A for a Separate Motor]

By using the fitting difference, the user can easily mount a separately manufactured motor bracket.

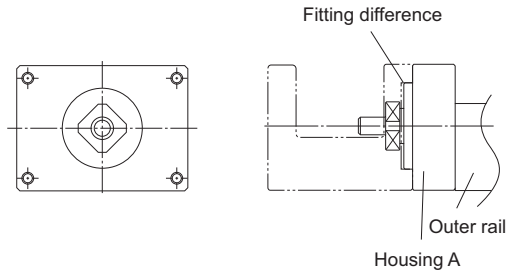

### [Turnaround Housing A]

Since the mounting holes are drilled in constant pitches, the user can easily select a direction to mount the turnaround section.

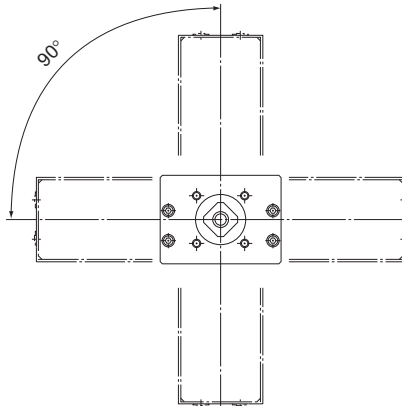

# Intermediate Flange

## [Motor Used and Applicable Intermediate Flanges for Model SKR]

Several types of intermediate flanges for mounting motors are available for model SKR. Specify an intermediate flange that matches the motor used.

Each intermediate flange is made of steel and provided with THK AP-C treatment, a surface treatment that provides excellent corrosion resistance.

Table16 Table of Motors Used and Corresponding Intermediate Flanges

Motor type		Rated output	Flange size	SKR20	SKR26	SKR33	SKR46	SKR55	SKR65			
AC servo motor	Yaskawa Electric	$\Sigma$ -Vmini	□25	SGMMV-A1	10W	AN	AN	—	—	—		
				SGMMV-A2	20W	AN	AN	—	—	—		
				SGMMV-A3	30W	AN	AN	—	—	—		
		$\Sigma$ -V	□40	SGMJV-A5	50W	AQ	AQ	AQ	AQ	—	—	
				SGMAV-A5		AQ	AQ	AQ	AQ	—	—	
			□40	SGMJV-01	100W	—	—	AQ	AQ	—	—	
				SGMAV-01		—	—	AQ	AQ	—	—	
				SGMAV-C2		150W	—	—	—	AQ	—	—
			□60	SGMJV-02	200W	—	—	—	AV	A0	AV	
				SGMAV-02		—	—	—	AV	A0	AV	
				SGMJV-04	400W	—	—	—	AV	A0	AV	
				SGMAV-04		—	—	—	AV	A0	AV	
				□80	SGMAV-06	550W	—	—	—	—	A0	AV
		SGMJV-08			750W	—	—	—	—	AZ	AZ	
	SGMAV-08	—	—	—		—	AZ	AZ				
	Mitsubishi Electric	MELSERVO	J2-Jr	□28	HC-AQ013	10W	AM	AM	—	—	—	
					HC-AQ023	20W	AM	AM	—	—	—	
					HC-AQ033	30W	AM	AM	—	—	—	
			□40	HG-KR053	50W	AQ	AQ	AQ	AQ	—	—	
				HG-MR053		AQ	AQ	AQ	AQ	—	—	
				HG-KR13	100W	—	—	AQ	AQ	—	—	
				HG-MR13		—	—	AQ	AQ	—	—	
				□60	HG-KR23	200W	—	—	—	AV	A0	AV
					HG-MR23		—	—	—	AV	A0	AV
			HG-KR43		400W	—	—	—	AV	A0	AV	
			HG-MR43			—	—	—	AV	A0	AV	
			□80	HG-KR73	750W	—	—	—	—	AZ	AZ	
HG-MR73				—		—	—	—	AZ	AZ		
J3			□25	HG-AK0136	10W	AN	AN	—	—	—	—	
		HG-AK0236		20W	AN	AN	—	—	—	—		
		HG-AK0336		30W	AN	AN	—	—	—	—		
		□40	HF-MP053	50W	AQ	AQ	AQ	AQ	—	—		
			HF-KP053		AQ	AQ	AQ	AQ	—	—		
			HF-MP13	100W	—	—	AQ	AQ	—	—		
		HF-KP13	—		—	AQ	AQ	—	—			
		□60	HF-MP23	200W	—	—	—	AV	A0	AV		
			HF-KP23		—	—	—	AV	A0	AV		
			HF-MP43	400W	—	—	—	AV	A0	AV		
			HF-KP43		—	—	—	AV	A0	AV		
		□80	HF-MP73	750W	—	—	—	—	AZ	AZ		
			HF-KP73		—	—	—	—	AZ	AZ		

Motor type			Rated output	Flange size	SKR20	SKR26	SKR33	SKR46	SKR55	SKR65		
AC servo motor	Toshiba Sasaki Co., Ltd.	TBL-I-II	TS4602	50W	□40	AQ	AQ	AQ	AQ	—	—	
			TS4603	100W		—	—	AQ	AQ	—	—	
			TS4607	200W	□60	—	—	—	AV	A0	AV	
			TS4609	400W		—	—	—	AV	A0	AV	
			TS4614	750W	□80	—	—	—	—	AZ	AZ	
	Panasonic Corp.	MINAS	A5	MSMD5A	50W	□38	AP	AP	AP	AP	—	—
				MSME5A			AP	AP	AP	AP	—	—
				MSMD01	100W		—	—	AP	AP	—	—
				MSME01			—	—	AP	AP	—	—
			MSMD02	200W	□60	—	—	—	AY	—	—	
			MSME02			—	—	—	AY	—	—	
			MSMD04	400W		—	—	—	AY	—	—	
			MSME04			—	—	—	AY	—	—	
		MSMD08	750W	□80	—	—	—	—	A5	A5		
		MSME08			—	—	—	—	A5	A5		
		MSMD5A	50W		□38	AP	AP	AP	AP	—	—	
		MSMD01	100W			—	—	AP	AP	—	—	
		MQMA01		200W	□60	—	—	—	AY	—	—	
		MSMD02	—			—	—	AY	—	—		
		MAMA02	400W	—		—	—	AY	—	—		
		MSMD04		—		—	—	AY	—	—		
		MSMA04	750W	□80	—	—	—	AY	—	—		
	MSMD08	—			—	—	—	A5	A5			
	MAMA08	—	—		—	—	A5	A5				
	SANYO DENKI	SANMOTION R	E		MUMA02	200W	□60	—	—	—	—	—
				MUMA04	400W	—		—	—	—	—	
				R2AA04003	30W	□40		AQ	AQ	AQ	AQ	—
R2AA04005				50W	AQ			AQ	AQ	AQ	—	—
R2AA04010				100W	—			—	AQ	AQ	—	—
R2AA06020	200W	□60	—	—	—	AV	A0	AV				
R2AA06040	400W		—	—	—	AV	A0	AV				
Omron	OMNUC G5	G	R88M-K05030	50W	□40	AQ	AQ	AQ	AQ	—	—	
			R88M-K10030	100W		—	—	AQ	AQ	—	—	
			R88M-K20030	200W		□60	—	—	—	AY	—	—
			R88M-K40030	400W	—		—	—	AY	—	—	
			R88M-K75030	750W	□80	—	—	—	—	A5	A5	
	R88M-G05030		50W	□40	AQ	AQ	AQ	AQ	—	—		
	R88M-G10030		100W		—	—	AQ	AQ	—	—		
	R88M-GP10030				—	—	—	AY	—	—		
	R88M-G20030		200W	□60	—	—	—	AY	—	—		
R88M-G40030	400W	—	—		—	AY	—	—				
R88M-G75030	750W	□80	—	—	—	—	A5	A5				
Fanuc	βis series	G	βis0.2/5000	50W	□40	AQ	AQ	AQ	AQ	—	—	
			βis0.3/5000	100W		—	—	AQ	AQ	—	—	
			βis0.4/5000	130W	□60	—	—	—	AV	A0	AV	
			βis0.5/6000	350W		—	—	—	AV	A0	AV	
			βis1/6000	500W		—	—	—	AV	A0	AV	

		Motor type		Rated output	Flange size	SKR20	SKR26	SKR33	SKR46	SKR55	SKR65	
AC servo motor	Keyence Corporation	SV	SV-M005	50W	□40	AQ	AQ	AQ	AQ	—	—	
			SV-M010	100W		—	—	AQ	AQ	—	—	
			SV-M020	200W	□60	—	—	—	AV	A0	AV	
			SV-M040	400W		—	—	—	AV	A0	AV	
			SV-M075	750W		□80	—	—	—	—	AZ	AZ
		MV	MV-M05	50W	□40	AQ	AQ	AQ	AQ	—	—	
			MV-M10	100W		—	—	AQ	AQ	—	—	
			MV-M20	200W	□60	—	—	—	AV	A0	AV	
			MV-M40	400W		—	—	—	AV	A0	AV	
			MV-M75	750W		□76	—	—	—	—	A5	A5
	Stepping motor	Oriental Motor	α Step	AR2 *		□28	AS	AS	—	—	—	—
				AR/ARL46 *, AZ46 *		□42	AR	AR	AR	—	—	—
				AR/ARL6 *, AZ6 *		□60	—	—	AU	AU	—	—
				AR/ARL9 *, AS9 *		□85	—	—	—	—	A6	A6
5 phase			CRK	CRK52 *		□28	AS	AS	—	—	—	—
				CRK54 *		□42	AR	AR	AR	—	—	—
				CRK56 *		□60	—	—	AU	AU	—	—
			CVK	CVK52 *		□28	AS	AS	—	—	—	—
				CVK54 *		□42	AR	AR	AR	—	—	—
				CVK56 *		□60	—	—	AU	AU	—	—
				RKS54 *		□42	AR	AR	AR	—	—	—
				RKS56 *		□60	—	—	AU	AU	—	—
RKS59 *				□85	—	—	—	—	A6	A6		
2 phase			CMK	CMK22 *		□28	AS	AS	—	—	—	—
		CMK24 *			□42	AR	AR	AR	—	—	—	
		CMK26 *			□56.4	—	—	AT	—	—	—	
		CVK	CVK22 *		□28	AS	AS	—	—	—	—	
			CVK24 *		□42	AR	AR	AR	—	—	—	
			CVK26 *		□56.4	—	—	AT	—	—	—	
SANYO DENKI		PB	PBDM28 *		□28	AS	AS	—	—	—	—	
			PBDM423		□42	AR	AR	AR	—	—	—	
			PBDM60 *		□60	—	—	AU	AU	—	—	
			PB * R423, PB * P423		□42	AR	AR	AR	—	—	—	
			PB * R60 *, PB * P60 *		□60	—	—	AU	AU	—	—	
		5 phase	FAF/FDF52 *		□28	AS	AS	—	—	—	—	
			FAF/FDF55 *		□42	AR	AR	AR	—	—	—	
			FAF/FDF78 *		□60	—	—	AU	AU	—	—	
			FSF55 *		□42	AR	AR	AR	—	—	—	
	FSF78 *			□60	—	—	AU	AU	—	—		
	2 phase	DU14S28 *		□28	AS	AS	—	—	—	—		
		DU15H52 *		□42	AR	AR	AR	—	—	—		
		DU16H71 *		□56	—	—	AT	—	—	—		
		DB14S28 *		□28	AS	AS	—	—	—	—		
DB15H52 *			□42	AR	AR	AR	—	—	—			
DB16H71 *		□56	—	—	AT	—	—	—				
DB16H78 *		□60	—	—	AU	AU	—	—				

Note1) The symbols in the table indicate the housing A and intermediate flange.

Note2) For motor coupling, contact THK.





SKR20

AR

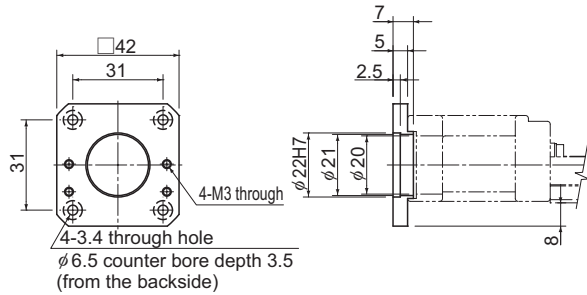

SKR20

AS

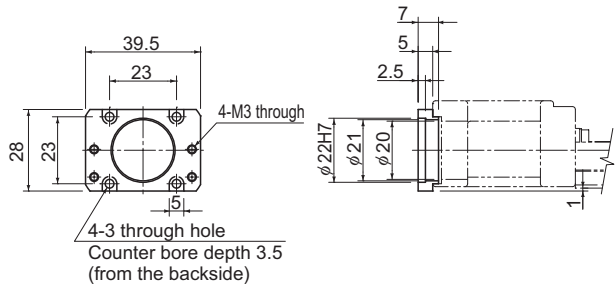

SKR20

AM

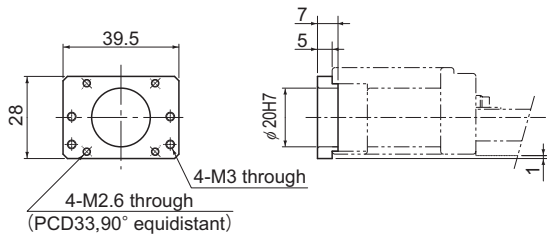

SKR20

AN

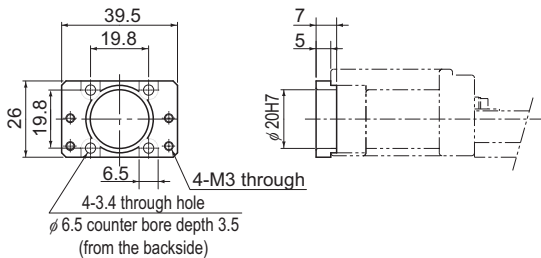

● For Model SKR26

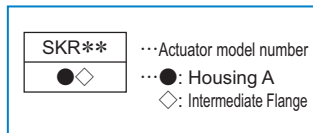

■ Housing A

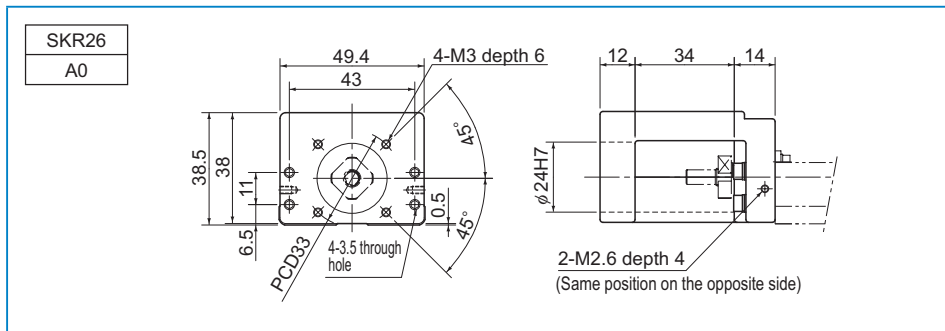

■ Intermediate Flange

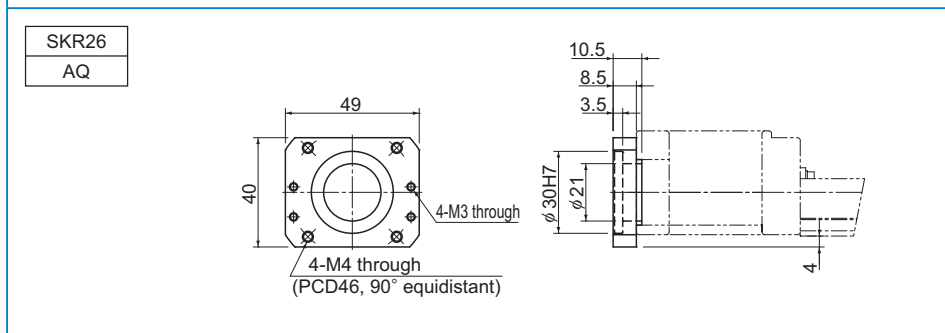
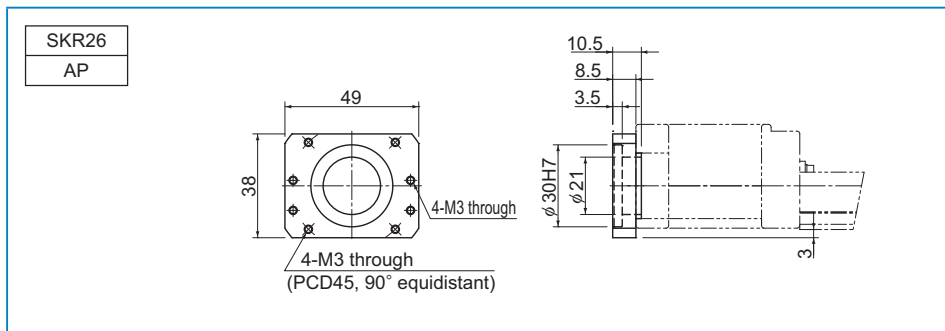

SKR26

AR

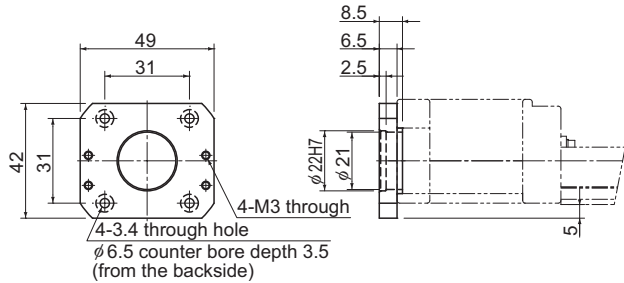

SKR26

AS

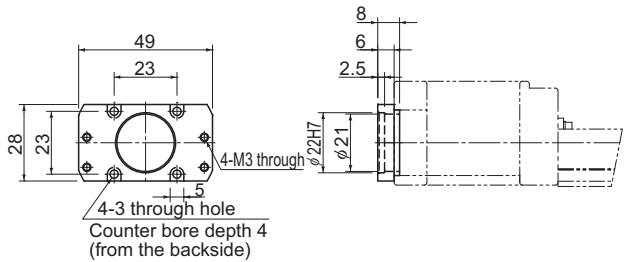

SKR26

AM

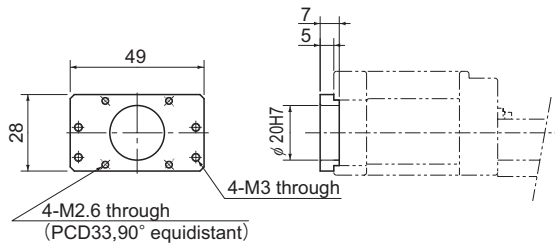

SKR26

AN

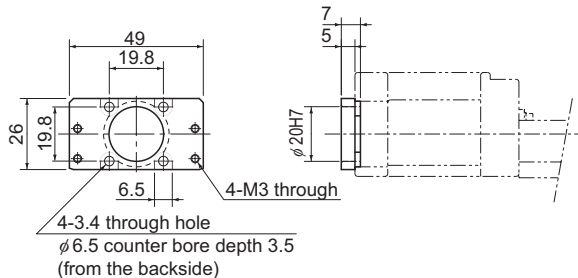

● For Model SKR33

SKR**	···· Actuator model number
●	···· Housing A
◇	◇ Intermediate Flange

■ Housing A

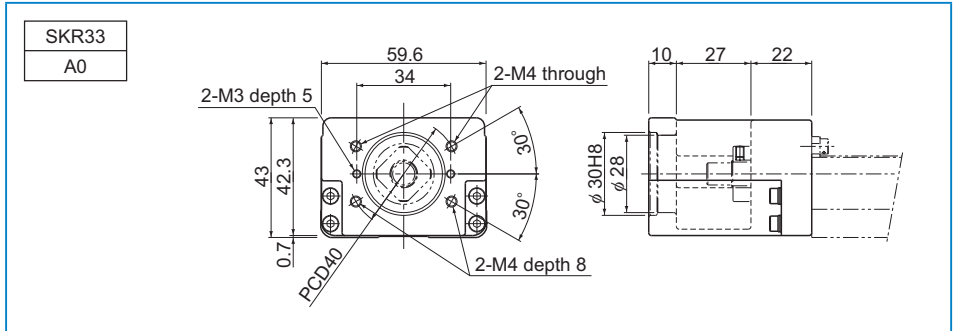

■ Intermediate Flange

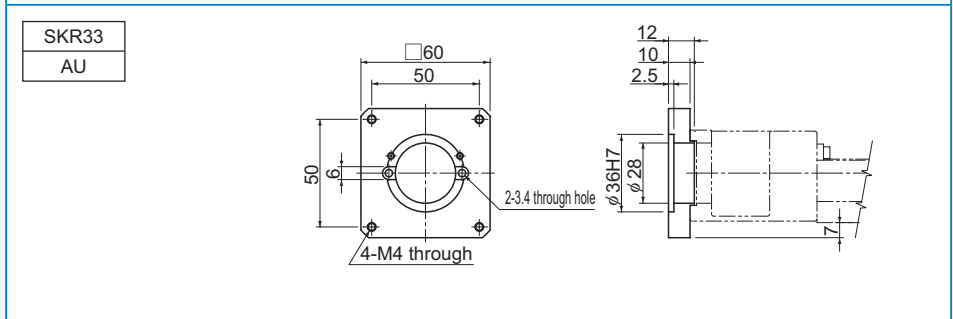
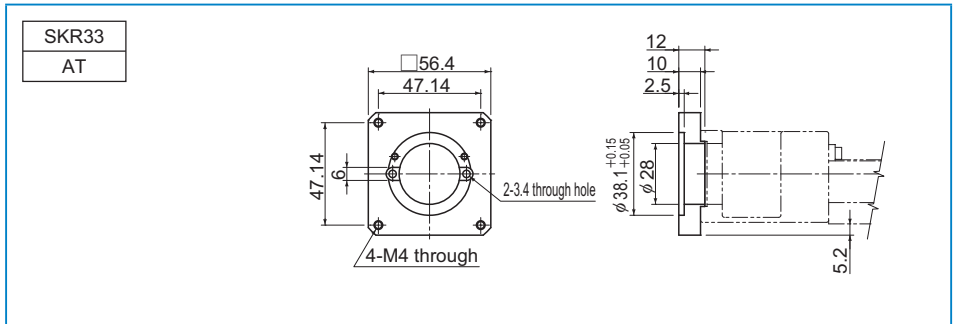

SKR33

AQ

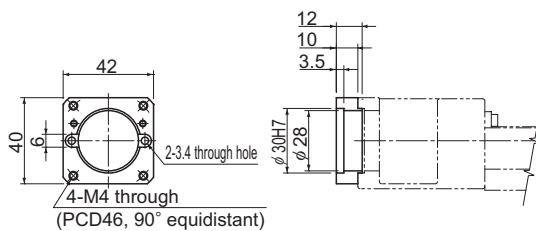

SKR33

AR

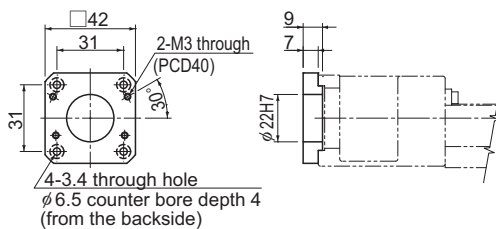

SKR33

AP

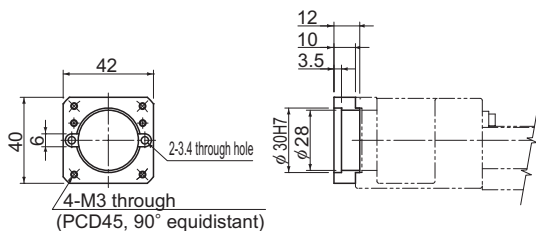

● For Model SKR46

SKR**	···Actuator model number
● ◆	···●: Housing A ◆: Intermediate Flange

■ Housing A

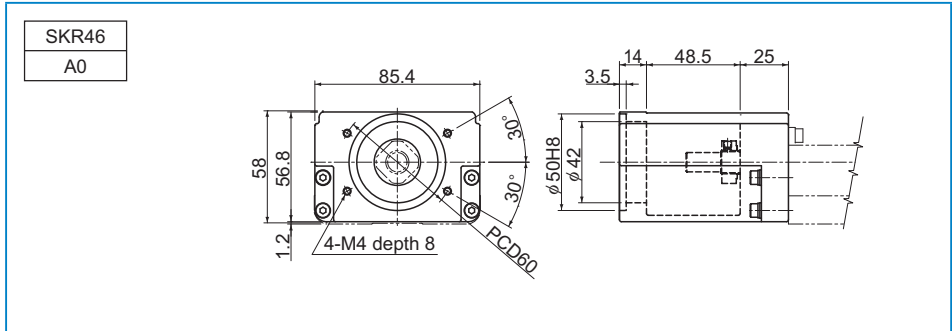

■ Intermediate Flange

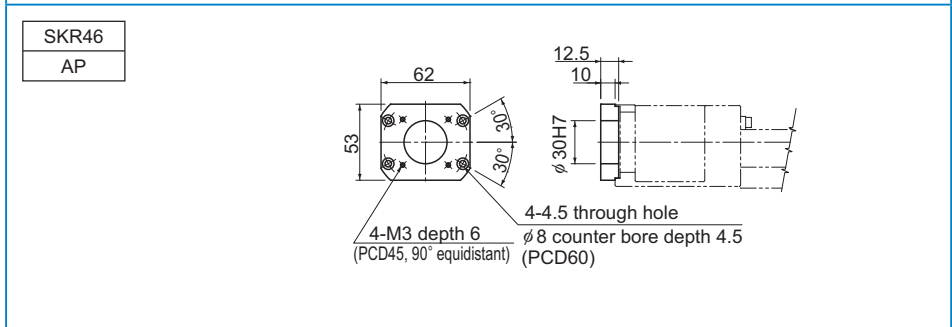
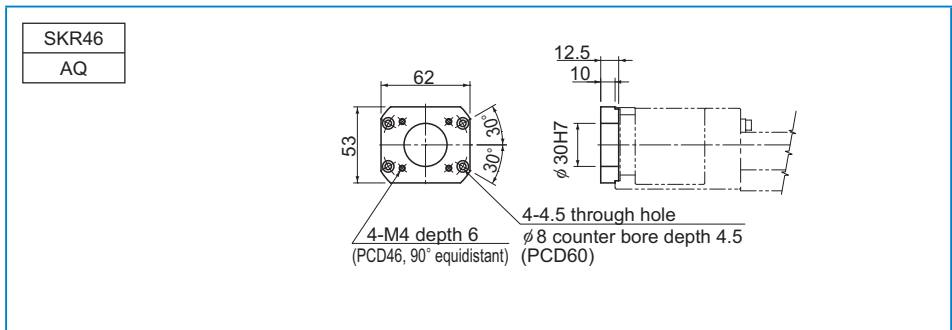

SKR46

AU

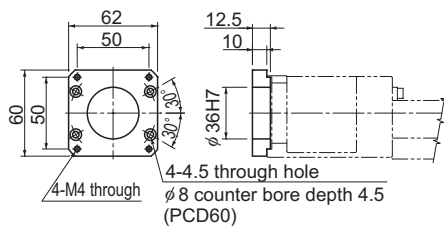

SKR46

AY

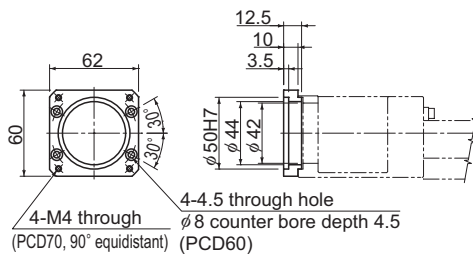

SKR46

AV

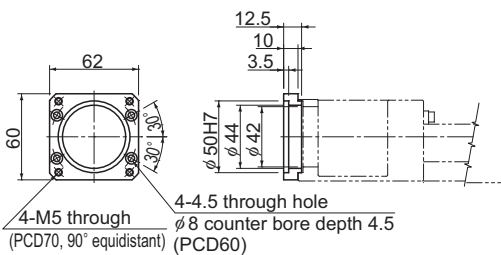



● For Model SKR55

SKR**	···· Actuator model number
●	···· Housing A
◇	◇ Intermediate Flange

■ Housing A

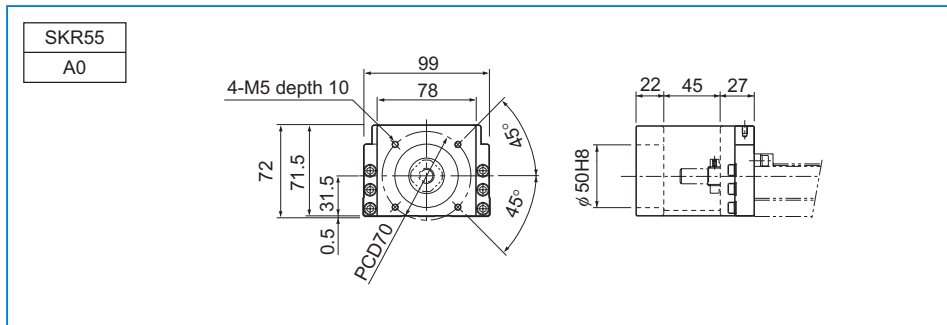

■ Turnaround Housing A

Note) Specify mounting holes when ordering.

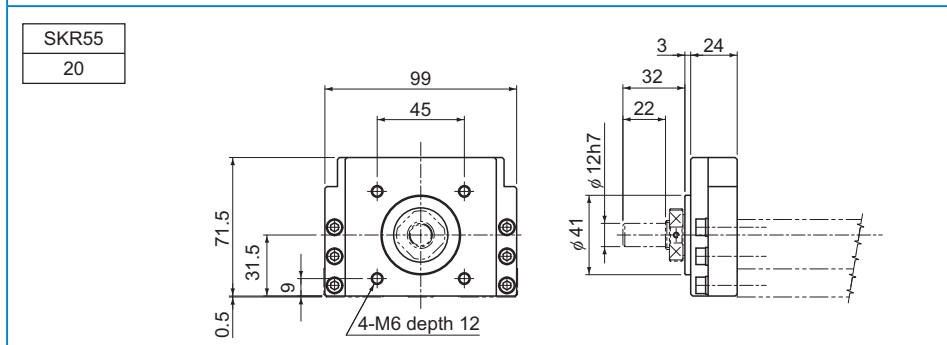
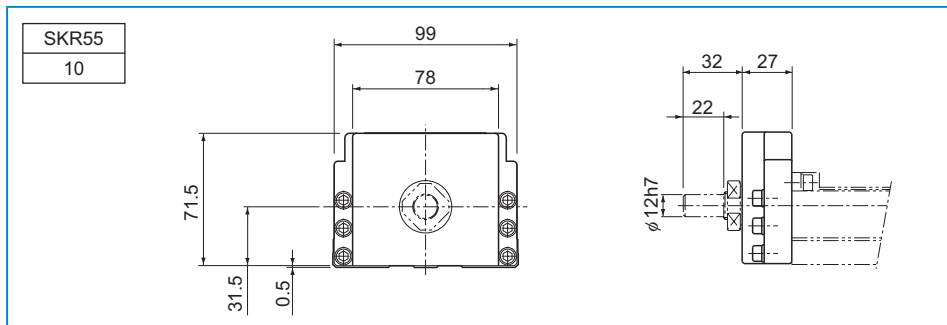

## Intermediate Flange

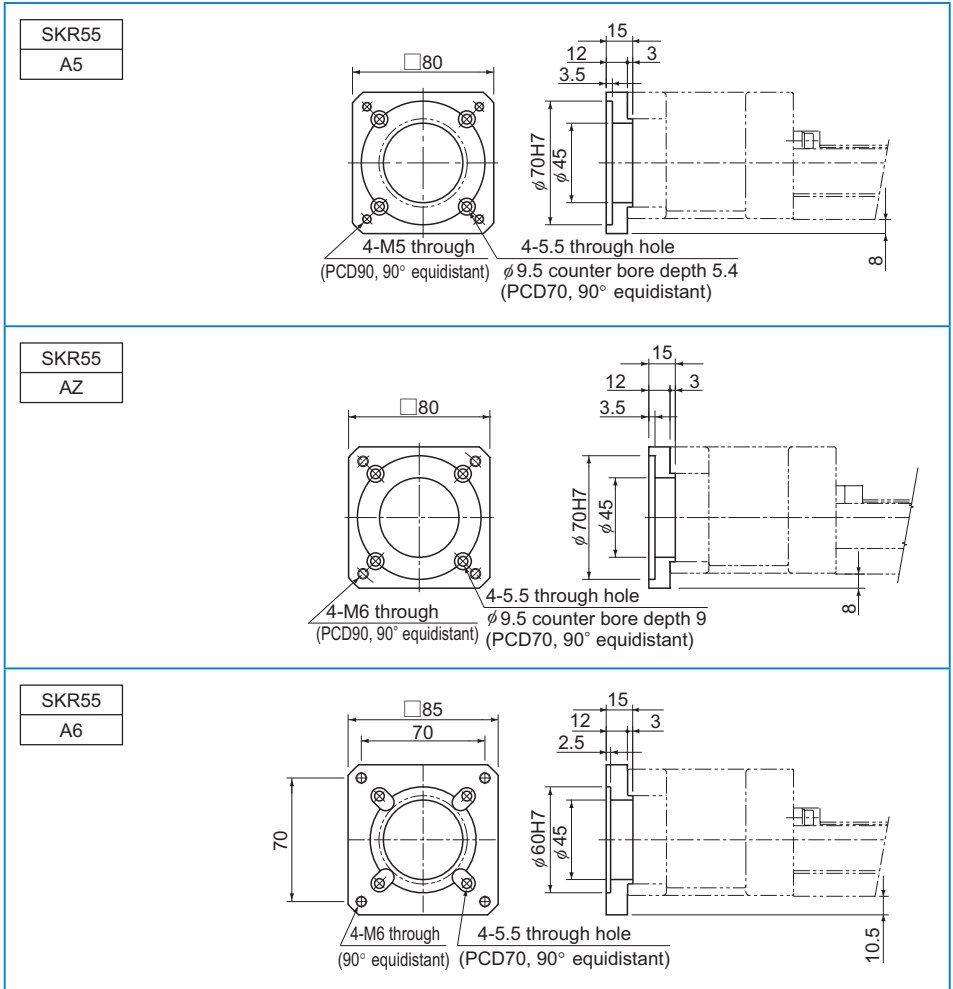

● For Model SKR65

SKR**	···· Actuator model number
●◇	····●: Housing A
	◇: Intermediate Flange

■ Housing A

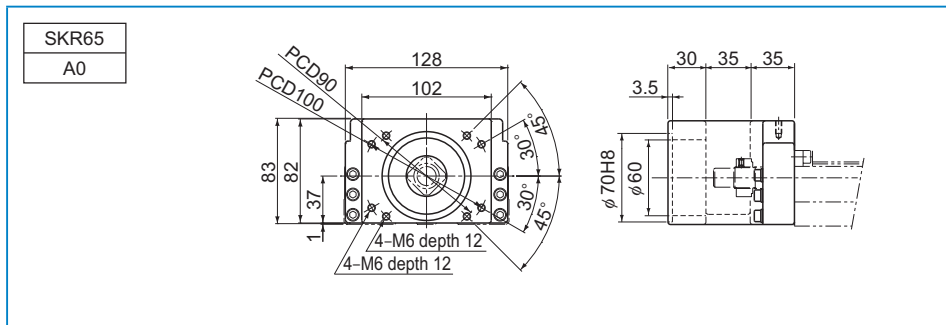

■ Turnaround Housing A

Note) Specify mounting holes when ordering.

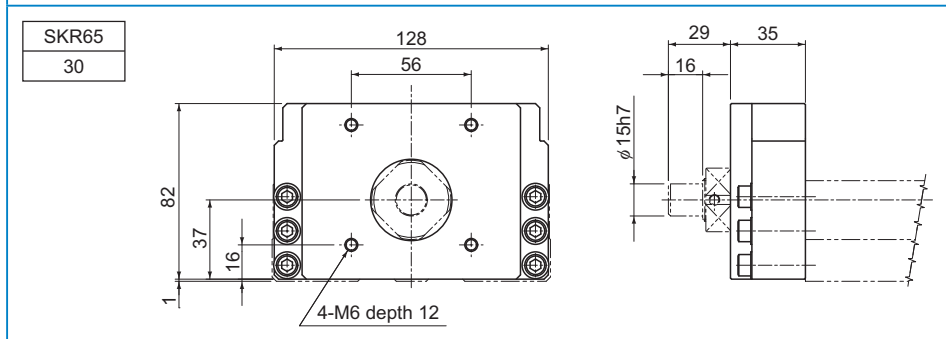
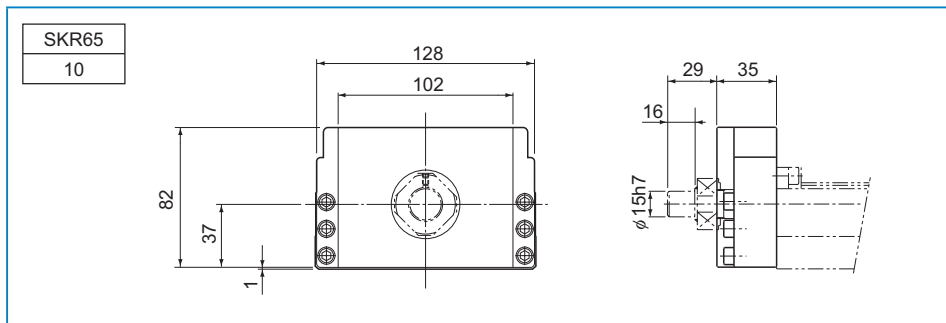

## Intermediate Flange

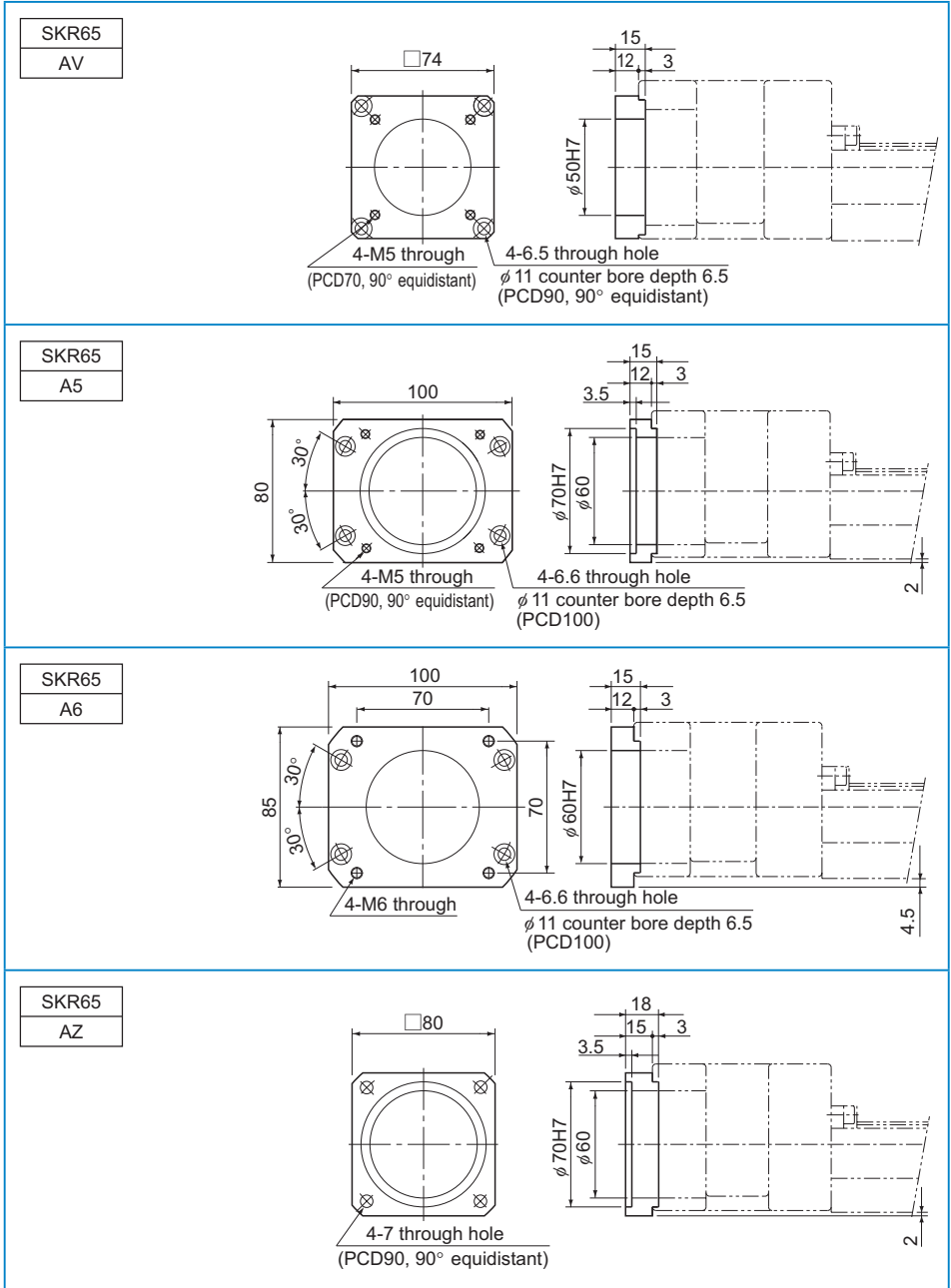

## Motor Wrap Type

Model SKR is available in "Motor Wrap" types that allow the motor to be turned around in order to minimize the dimension in the longitudinal direction. (Pulley ratio: 1:1). Contact THK for details.

