

SVR/SVS

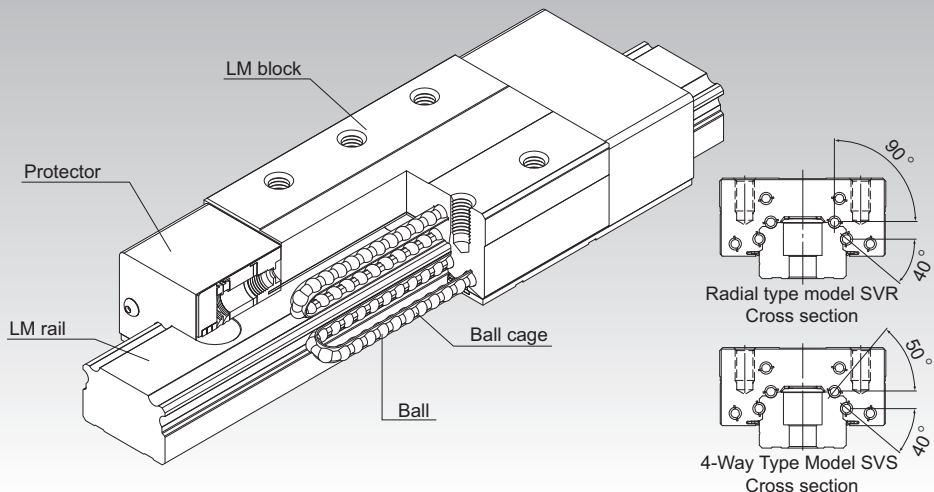

Caged Ball LM Guide Ultra-heavy Load Type for Machine Tools Model SVR/SVS



*For the Ball Cage, see **A1-88**.

Point of Selection **A1-10**

Point of Design **A1-434**

Options **A1-457**

Model No. **A1-522**

Precautions on Use **A1-528**

Accessories for Lubrication **A24-1**

Mounting Procedure and Maintenance **B1-89**

Equivalent moment factor **A1-43**

Rated Loads in All Directions **A1-58**

Equivalent factor in each direction **A1-60**

Radial Clearance **A1-70**

Accuracy Standards **A1-76**

Shoulder Height of the Mounting Base and the Corner Radius **A1-444**

Permissible Error of the Mounting Surface **A1-450**

Dimensions of Each Model with an Option Attached **A1-470**

Structure and Features

Models SVR/SVS have especially high rigidity and load carrying capacity among the Caged Ball LM Guide series. In addition, these models maintain the LM Guide performance and achieve high reliability through the strengthening of the dust proof performance with a broad range of options that take into account the service environments of machine tools, etc.

*Since models SVR/SVS have very high rigidity, their structures are easily affected by the misalignment of the mounting surface and the installation error. If affected by these factors, their service life may be shortened or their motion may be disrupted. When considering using these models, contact THK.

[Super Heavy Load, Increased Damping]

The raceway of models SVR/SVS adopts a circular-arc deep groove with a curvature approximate to the ball diameter. Since the ball contact area increases as the applied load increases, a large load carrying capacity is achieved and damping is also improved.

[Increased Dust-proof Performance]

The foreign material removal function is improved with a newly developed protector to strengthen the dust-proof performance. In addition, use of a side scraper reduces the entrance of foreign material into the LM block, thus maintaining the LM Guide performance for a long period even in adverse environments.

[High Rigidity]

Models SVR/SVS achieve the highest rigidity among the Caged Ball LM Guide series. Both the radial type SVR and the 4-way equal load type SVS are available for the same size. Depending on the intended use, you can select either type.

[Wide Array of Options]

Various options are available, including end seal, inner seal, side seal, Laminated Contact Scraper LaCS, protector, side scraper and Cap GC, to respond to diversified service environments.

[Models SVR/SVS Contamination Protection Performance Evaluation]

Models SVR/SVS maintain their performance under severe conditions with fine particles or liquid contamination.

Test conditions

Item		Description
Tested model		SVS45LR1TTHHYC1+2880LP×2set
Maximum speed		200m/min
Stroke		2500mm
Grease used		THK AFB-LF Grease
Environmental conditions	Foreign material	Type: Metal powder (Atomized Powder) (particle diameter: 125 μm or less)
		Amount: 0.4 g/20 min
	Coolant	Water-soluble coolant
		Amount: 0.2 cc/10 s

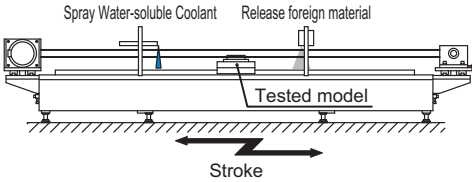

Test equipment

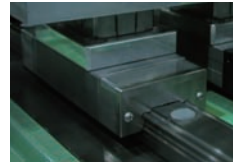

Tested model

Models SVR/SVS with option (TTHHY option)

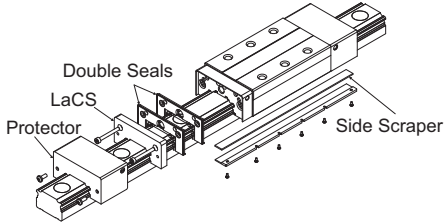

TTHHY Option:

Double Seals
Laminated Contact Scraper LaCS
Protector
Side Scraper

Test Result



After traveling 3000 km

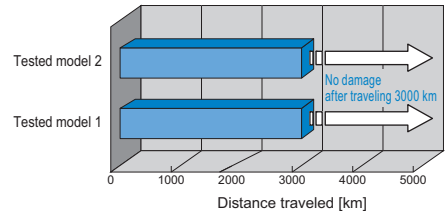

Models SVR/SVS maintain their performance even after traveling 3000 km under severe conditions with exposure to coolant and contamination.

Types and Features

Models SVR-R/SVS-R

With this type, the LM block has a smaller width (W) and tapped holes.

Used in places where the space for table width is limited.

Specification Table⇒ [A1-122](#)/[A1-124](#)

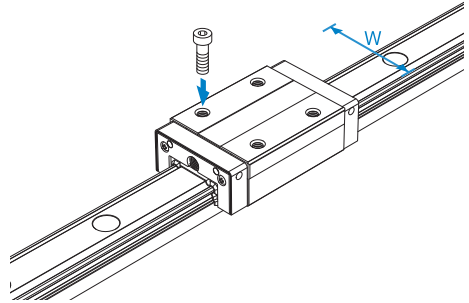

Models SVR-LR/SVS-LR

The LM block has the same cross-sectional shape as models SVR/SVS-R, but has a longer overall LM block length (L) and a greater rated load.

Specification Table⇒ [A1-122](#)/[A1-124](#)

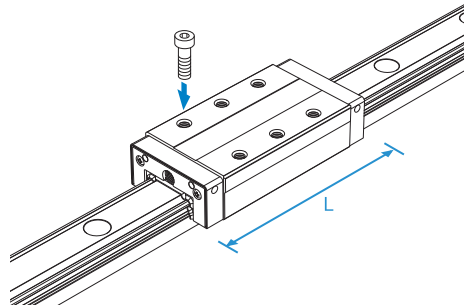

Models SVR-C/SVS-C

The flange of the LM block has tapped holes. Can be mounted from the top or the bottom.

Can also be used in places where the table cannot have through holes for mounting bolts.

Specification Table⇒ [A1-126](#)/[A1-128](#)

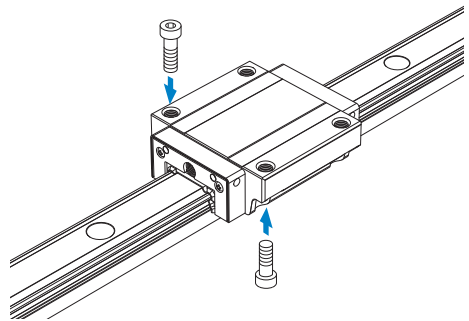

Models SVR-LC/SVS-LC

The LM block has the same cross-sectional shape as models SVR/SVS-C, but has a longer overall LM block length (L) and a greater rated load.

Specification Table⇒ [A1-126/A1-128](#)

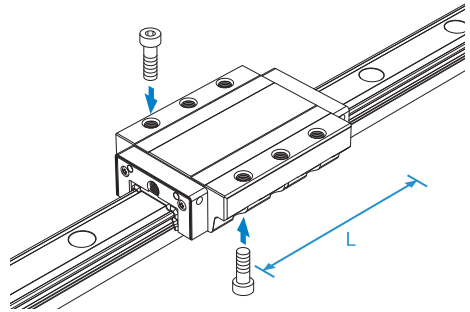

Models SVR-RH/SVS-RH

The dimensions are almost the same as that of LM Guide models SHS and HSR, and the LM block has tapped holes.

Specification Table⇒ [A1-130](#)

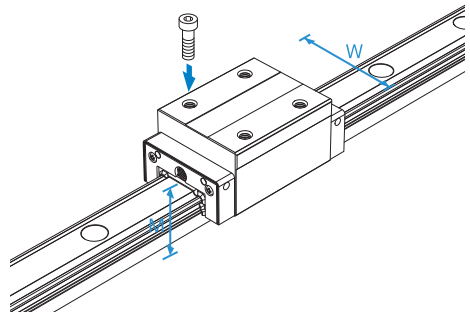

Models SVR-LRH/SVS-LRH

The LM block has the same cross-sectional shape as models SVR/SVS-RH, but has a longer overall LM block length (L) and a greater rated load.

Specification Table⇒ [A1-130](#)

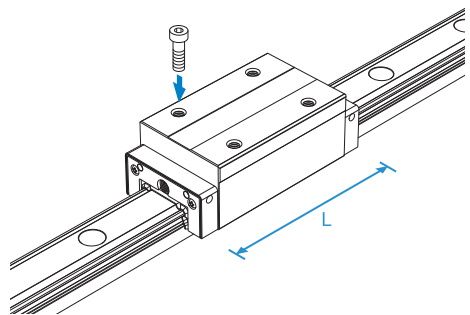

Models SVR-CH/SVS-CH

The dimensions are similar to that of LM Guide models SHS and HSR, and the flange of the LM block has tapped holes.

Specification Table⇒ **A1-132**

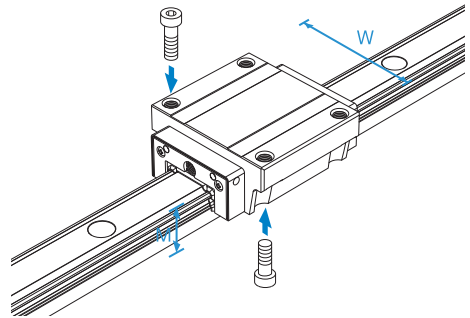

LM Guide

Models SVR-LCH/SVS-LCH

The LM block has the same cross-sectional shape as models SVR/SVS-CH, but has a longer overall LM block length (L) and a greater rated load.

Specification Table⇒ **A1-132**

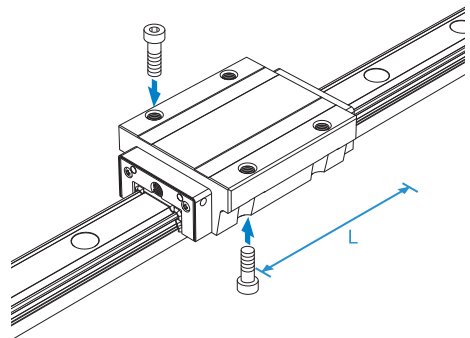

Models SVR-R and SVR-LR

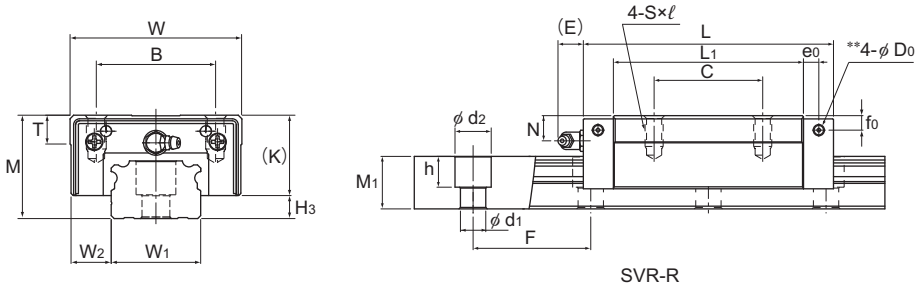

Model No.	Outer dimensions			LM block dimensions													Grease nipple	H ₃
	Height	Width	Length	B	C	S × ℓ	L ₁	T	K	N	f ₀	E	e ₀	D ₀				
	M	W	L	B	C	S × ℓ	L ₁	T	K	N	f ₀	E	e ₀	D ₀		H ₃		
SVR 25R SVR 25LR	31	50	82.8 102	32	35 50	M6 × 8	61.4 80.6	9.7	25.5	7.8	5.1	12	4.5	3.9	B-M6F	5.5		
SVR 30R SVR 30LR	38	60	98 120.5	40	40 60	M8 × 10	72.1 94.6	9.7	31	10.3	7	12	6.5	3.9	B-M6F	7		
SVR 35R SVR 35LR	44	70	109.5 135	50	50 72	M8 × 12	79 104.5	11.7	35	12.1	8	12	6	5.2	B-M6F	9		
SVR 45R SVR 45LR	52	86	138.2 171	60	60 80	M10 × 17	105 137.8	14.7	40.4	13.9	8	16	8.5	5.2	B-PT1/8	11.6		
SVR 55R SVR 55LR	63	100	163.3 200.5	65	75 95	M12 × 18	123.6 160.8	17.7	49	16.6	10	16	10	5.2	B-PT1/8	14		
SVR 65R SVR 65LR	75	126	186 246	76	70 110	M16 × 20	143.6 203.6	21.6	60	19	15	16	8.7	8.2	B-PT1/8	15		

Model number coding

SVR45	LR	2	QZ	TTHH	C0	+1200L	P	T	-II
Model No.	Type of LM block	No. of LM blocks used on the same rail	With QZ Lubricator	Contamination protection accessory symbol (*1)	LM rail length (in mm)	Radial clearance symbol (*2)	Symbol for LM rail jointed use	Accuracy symbol (*3)	Symbol for No. of rails used on the same plane (*4)
					Normal (No symbol)	Light preload (C1)	Normal grade (No Symbol)/High accuracy grade (H)	Normal grade (No Symbol)/Super precision grade (SP)	
					Medium preload (C0)		Ultra precision grade (UP)		

(*1) See contamination protection accessory on **A1-494**. (*2) See **A1-70**. (*3) See **A1-76**. (*4) See **A1-13**.

Note) This model number indicates that an LM block and an LM rail constitute one set (i.e., the required number of sets when 2 rails are used in parallel is 2). Those models equipped with QZ Lubricator cannot have a grease nipple. When desiring a grease nipple for a model attached with QZ, contact THK.

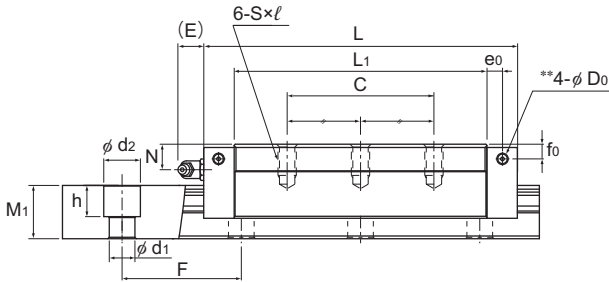

SVR-LR

Unit: mm

	LM rail dimensions					Basic load rating		Static permissible moment kN-m*					Mass	
	Width W_1 0 -0.05	Height M_1	Pitch F	Length $d_1 \times d_2 \times h$ Max*	C kN	C_0 kN	M_A		M_B		M_C	LM block kg	LM rail kg/m	
							1 block	Double blocks	1 block	Double blocks	1 block			
25	12.5	17	40	6×9.5×8.5	3000	48.2 57	68.1 86.3	0.602 0.944	3.02 4.67	0.365 0.57	1.83 2.81	0.71 0.9	0.4 0.5	2.9
28	16	21	80	7×11×9	3000	67.9 84	91.6 124	0.907 1.64	4.85 7.92	0.552 0.991	2.94 4.76	1.08 1.47	0.7 0.9	4.2
34	18	24.5	80	9×14×12	3000	89.6 112	116 160	1.26 2.35	6.91 11.5	0.769 1.42	4.2 6.91	1.64 2.26	1 1.3	6.0
45	20.5	29	105	14×20×17	3090	138 161	186 233	2.76 4.52	13.7 22.1	1.67 2.74	8.3 13.4	3.5 4.6	1.8 2.3	9.5
53	23.5	36.5	120	16×23×20	3060	177 214	235 309	3.99 6.8	20.6 32.7	2.42 4.1	12.4 19.7	5.07 6.67	3.3 4.3	14
63	31.5	43	150	18×26×22	3000	271 339	352 484	7.26 13.5	34.9 62.6	4.4 8.14	21.1 37.6	9 12.4	6.0 8.5	19.6

Note) Pilot holes for side nipples** are not drilled through in order to prevent foreign material from entering the product. THK will mount grease nipples per your request. Therefore, do not use the side nipple pilot holes** for purposes other than mounting a grease nipple.

In case of oil lubrication, be sure to let THK know the mounting orientation and the exact position in each LM block where the piping joint should be attached.

For the mounting orientation and the lubrication, see [A1-12](#) and [A24-2](#), respectively.

The maximum length under "Length*" indicates the standard maximum length of an LM rail. (See [A1-134](#).)

Static permissible moment*: 1 block: static permissible moment value with 1 LM block

Double blocks: static permissible moment value with 2 blocks closely contacting with each other

Models SVS-R and SVS-LR

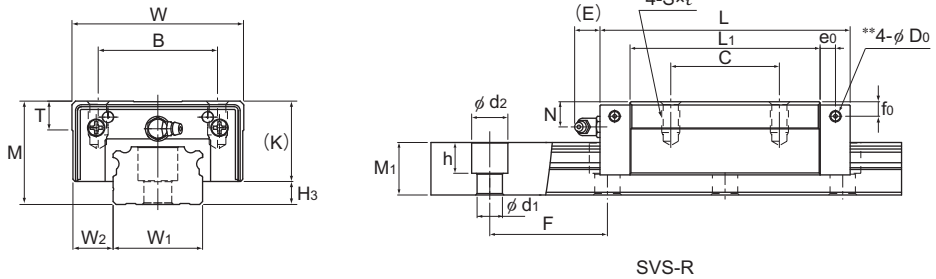

Model No.	Outer dimensions			LM block dimensions													Grease nipple	H ₃
	Height	Width	Length	B	C	S×ℓ	L ₁	T	K	N	f ₀	E	e ₀	D ₀				
	M	W	L															
SVS 25R SVS 25LR	31	50	82.8 102	32	35 50	M6×8	61.4 80.6	9.7	25.5	7.8	5.1	12	4.5	3.9	B-M6F	5.5		
SVS 30R SVS 30LR	38	60	98 120.5	40	40 60	M8×10	72.1 94.6	9.7	31	10.3	7	12	6.5	3.9	B-M6F	7		
SVS 35R SVS 35LR	44	70	109.5 135	50	50 72	M8×12	79 104.5	11.7	35	12.1	8	12	6	5.2	B-M6F	9		
SVS 45R SVS 45LR	52	86	138.2 171	60	60 80	M10×17	105 137.8	14.7	40.4	13.9	8	16	8.5	5.2	B-PT1/8	11.6		
SVS 55R SVS 55LR	63	100	163.3 200.5	65	75 95	M12×18	123.6 160.8	17.7	49	16.6	10	16	10	5.2	B-PT1/8	14		
SVS 65R SVS 65LR	75	126	186 246	76	70 110	M16×20	143.6 203.6	21.6	60	19	15	16	8.7	8.2	B-PT1/8	15		

Model number coding

SVS45	LR	2	QZ	TTHH	C0	+1200L	P	T	-II
Model No.	Type of LM block	No. of LM blocks used on the same rail	With QZ Lubricator	Contamination protection accessory symbol (*1)	LM rail length (in mm) Radial clearance symbol (*2) Normal (No symbol) Light preload (C1) Medium preload (C0)	Symbol for LM rail jointed use	Accuracy symbol (*3) Normal grade (No Symbol)/High accuracy grade (H) Precision grade (P)/Super precision grade (SP) Ultra precision grade (UP)	Symbol for No. of rails used on the same plane (*4)	

(*1) See contamination protection accessory on **A1-494**. (*2) See **A1-70**. (*3) See **A1-76**. (*4) See **A1-13**.

Note) This model number indicates that an LM block and an LM rail constitute one set (i.e., the required number of sets when 2 rails are used in parallel is 2).
Those models equipped with QZ Lubricator cannot have a grease nipple. When desiring a grease nipple for a model attached with QZ, contact THK.

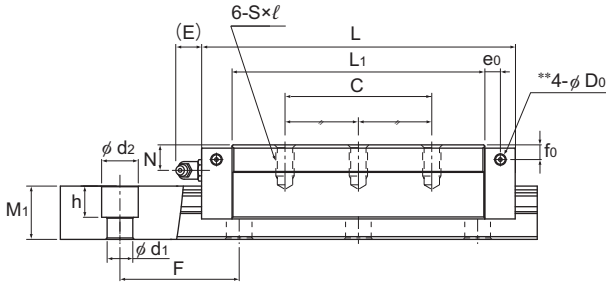

SVS-LR

Unit: mm

	LM rail dimensions					Basic load rating		Static permissible moment kN-m*					Mass	
	Width W_1 0 -0.05	Height M_1	Pitch F	Length $d_1 \times d_2 \times h$ Max*	C kN	C_0 kN	M_A 		M_B 		M_C 	LM block kg	LM rail kg/m	
							1 block	Double blocks	1 block	Double blocks	1 block			
25	12.5	17	40	6×9.5×8.5	3000	37 43.7	52.2 66.1	0.479 0.75	2.41 3.71	0.443 0.693	2.23 3.43	0.525 0.665	0.4 0.5	2.9
28	16	21	80	7×11×9	3000	52 64.4	70.1 95.2	0.722 1.31	3.86 6.3	0.667 1.21	3.58 5.83	0.798 1.08	0.7 0.9	4.2
34	18	24.5	80	9×14×12	3000	68.6 86.1	88.6 123	1 1.88	5.49 9.15	0.927 1.73	5.09 8.46	1.2 1.67	1 1.3	6.0
45	20.5	29	105	14×20×17	3090	105 123	142 178	2.19 3.58	10.9 17.5	2.02 3.31	10.1 16.2	2.6 3.44	1.8 2.3	9.5
53	23.5	36.5	120	16×23×20	3060	136 164	180 237	3.17 5.4	16.4 26	2.93 4.99	15.1 24	3.76 4.96	3.3 4.3	14
63	31.5	43	150	18×26×22	3000	208 260	269 370	5.76 10.7	27.7 49.6	5.33 9.88	25.6 45.8	6.66 9.16	6.0 8.5	19.6

Note) Pilot holes for side nipples** are not drilled through in order to prevent foreign material from entering the product.

THK will mount grease nipples per your request. Therefore, do not use the side nipple pilot holes** for purposes other than mounting a grease nipple.

In case of oil lubrication, be sure to let THK know the mounting orientation and the exact position in each LM block where the piping joint should be attached.

For the mounting orientation and the lubrication, see [A1-12](#) and [A24-2](#), respectively.

The maximum length under "Length*" indicates the standard maximum length of an LM rail. (See [A1-134](#).)

Static permissible moment*: 1 block: static permissible moment value with 1 LM block

Double blocks: static permissible moment value with 2 blocks closely contacting with each other

Models SVR-C and SVR-LC

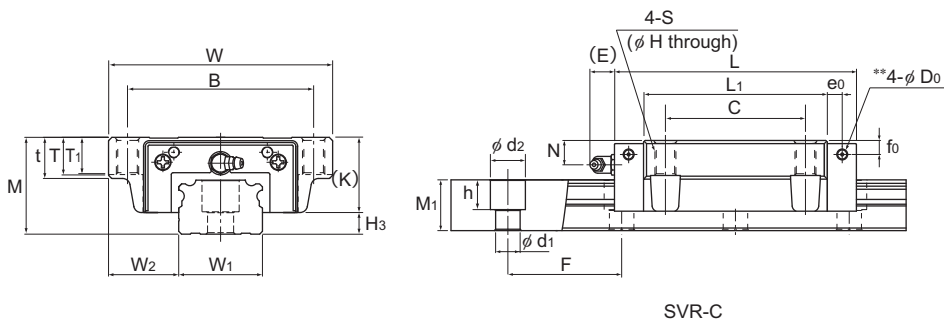

SVR-C

Model No.	Outer dimensions			LM block dimensions																H ₃
	Height	Width	Length	B	C	S	H	L ₁	t	T	T ₁	K	N	f ₀	E	e ₀	D ₀	Grease nipple		
	M	W	L																	
SVR 25C SVR 25LC	31	72	82.8 102	59	45	M8	6.8	61.4 80.6	16	14.8	12	25.5	7.8	5.1	12	4.5	3.9	B-M6F	5.5	
SVR 30C SVR 30LC	38	90	98 120.5	72	52	M10	8.5	72.1 94.6	18.1	16.9	14	31	10.3	7	12	6.5	3.9	B-M6F	7	
SVR 35C SVR 35LC	44	100	109.5 135	82	62	M10	8.5	79 104.5	20.1	18.9	16	35	12.1	8	12	6	5.2	B-M6F	9	
SVR 45C SVR 45LC	52	120	138.2 171	100	80	M12	10.5	105 137.8	22.1	20.6	20	40.4	13.9	8	16	8.5	5.2	B-PT1/8	11.6	
SVR 55C SVR 55LC	63	140	163.3 200.5	116	95	M14	12.5	123.6 160.8	24	22.5	22	49	16.6	10	16	10	5.2	B-PT1/8	14	
SVR 65C SVR 65LC	75	170	186 246	142	110	M16	14.5	143.6 203.6	28	26	25	60	19	15	16	8.7	8.2	B-PT1/8	15	

Model number coding

SVR45 LC 2 QZ TTHH C0 +1200L P T -II

Model No.

Type of LM block

With QZ Lubricator

Contamination protection accessory symbol (*1)

LM rail length (in mm)

Radial clearance symbol (*2)

Normal (No symbol)

Light preload (C1)

Medium preload (C0)

Symbol for LM rail jointed use

Accuracy symbol (*3)

Normal grade (No Symbol)/High accuracy grade (H)

Precision grade (P)/Super precision grade (SP)

Ultra precision grade (UP)

Symbol for No. of rails used on the same plane (*4)

No. of LM blocks used on the same rail

(*1) See contamination protection accessory on **A1-494**. (*2) See **A1-70**. (*3) See **A1-76**. (*4) See **A1-13**.

Note) This model number indicates that an LM block and an LM rail constitute one set (i.e., the required number of sets when 2 rails are used in parallel is 2).

Those models equipped with QZ Lubricator cannot have a grease nipple. When desiring a grease nipple for a model attached with QZ, contact THK.

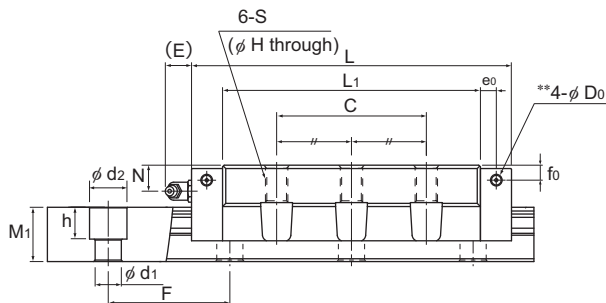

SVR-LC

Unit: mm

LM rail dimensions						Basic load rating		Static permissible moment kN-m*					Mass	
Width	Height	Pitch	Length	C	C ₀	M _A		M _B		M _C	LM block	LM rail		
W ₁ 0 -0.05	W ₂	M ₁	F	d ₁ × d ₂ × h	Max*	kN	kN	1 block	Double blocks	1 block	Double blocks	1 block	kg	kg/m
25	23.5	17	40	6 × 9.5 × 8.5	3000	48.2 57	68.1 86.3	0.602 0.944	3.02 4.67	0.365 0.57	1.83 2.81	0.71 0.9	0.6 0.8	2.9
28	31	21	80	7 × 11 × 9	3000	67.9 84	91.6 124	0.907 1.64	4.85 7.92	0.552 0.991	2.94 4.76	1.08 1.47	1.1 1.5	4.2
34	33	24.5	80	9 × 14 × 12	3000	89.6 112	116 160	1.26 2.35	6.91 11.5	0.769 1.42	4.2 6.91	1.64 2.26	1.6 2	6.0
45	37.5	29	105	14 × 20 × 17	3090	138 161	186 233	2.76 4.52	13.7 22.1	1.67 2.74	8.3 13.4	3.5 4.6	2.7 3.6	9.5
53	43.5	36.5	120	16 × 23 × 20	3060	177 214	235 309	3.99 6.8	20.6 32.7	2.42 4.1	12.4 19.7	5.07 6.67	4.5 5.9	14
63	53.5	43	150	18 × 26 × 22	3000	271 339	352 484	7.26 13.5	34.9 62.6	4.4 8.14	21.1 37.6	9 12.4	7.8 11.0	19.6

Note) Pilot holes for side nipples** are not drilled through in order to prevent foreign material from entering the product. THK will mount grease nipples per your request. Therefore, do not use the side nipple pilot holes** for purposes other than mounting a grease nipple.
 In case of oil lubrication, be sure to let THK know the mounting orientation and the exact position in each LM block where the piping joint should be attached.
 For the mounting orientation and the lubrication, see [A1-12](#) and [A24-2](#), respectively.
 The maximum length under "Length*" indicates the standard maximum length of an LM rail. (See [A1-134](#).)
 Static permissible moment*: 1 block: static permissible moment value with 1 LM block
 Double blocks: static permissible moment value with 2 blocks closely contacting with each other

Models SVS-C and SVS-LC

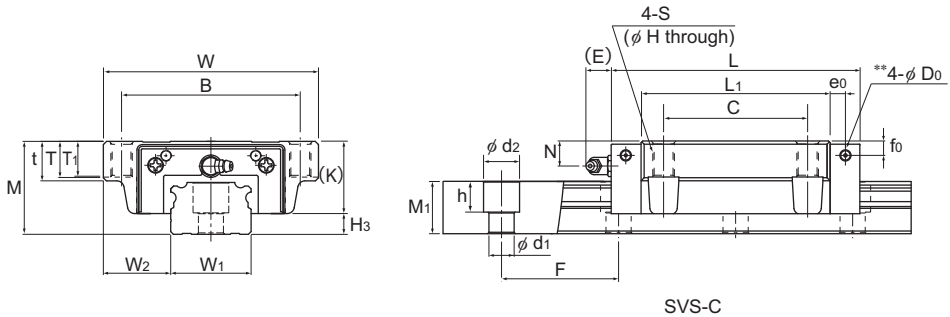

SVS-C

Model No.	Outer dimensions			LM block dimensions															Grease nipple	H ₃
	Height	Width	Length	B	C	S	H	L ₁	t	T	T ₁	K	N	f ₀	E	e ₀	D ₀			
	M	W	L	B	C	S	H	L ₁	t	T	T ₁	K	N	f ₀	E	e ₀	D ₀			
SVS 25C SVS 25LC	31	72	82.8 102	59	45	M8	6.8	61.4 80.6	16	14.8	12	25.5	7.8	5.1	12	4.5	3.9	B-M6F	5.5	
SVS 30C SVS 30LC	38	90	98 120.5	72	52	M10	8.5	72.1 94.6	18.1	16.9	14	31	10.3	7	12	6.5	3.9	B-M6F	7	
SVS 35C SVS 35LC	44	100	109.5 135	82	62	M10	8.5	79 104.5	20.1	18.9	16	35	12.1	8	12	6	5.2	B-M6F	9	
SVS 45C SVS 45LC	52	120	138.2 171	100	80	M12	10.5	105 137.8	22.1	20.6	20	40.4	13.9	8	16	8.5	5.2	B-PT1/8	11.6	
SVS 55C SVS 55LC	63	140	163.3 200.5	116	95	M14	12.5	123.6 160.8	24	22.5	22	49	16.6	10	16	10	5.2	B-PT1/8	14	
SVS 65C SVS 65LC	75	170	186 246	142	110	M16	14.5	143.6 203.6	28	26	25	60	19	15	16	8.7	8.2	B-PT1/8	15	

Model number coding

SVS45 LC 2 QZ TTHH C0 +1200L P T - II

Model No.	Type of LM block	With QZ Lubricator	Contamination protection accessory symbol (*1)	LM rail length (in mm)	Radial clearance symbol (*2)	Symbol for LM rail jointed use	Symbol for No. of rails used on the same plane (*4)
		No. of LM blocks used on the same rail		Normal (No symbol) Light preload (C1) Medium preload (C0)	Normal grade (No Symbol)/High accuracy grade (H) Precision grade (P)/Super precision grade (SP) Ultra precision grade (UP)		

(*1) See contamination protection accessory on **A1-494**. (*2) See **A1-70**. (*3) See **A1-76**. (*4) See **A1-13**.

Note) This model number indicates that an LM block and an LM rail constitute one set (i.e., the required number of sets when 2 rails are used in parallel is 2). Those models equipped with QZ Lubricator cannot have a grease nipple. When desiring a grease nipple for a model attached with QZ, contact THK.

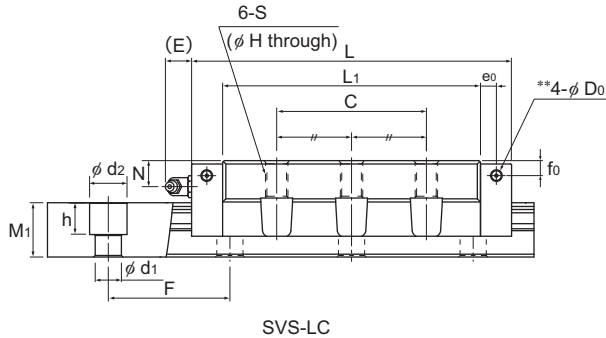

Unit: mm

LM rail dimensions					Basic load rating		Static permissible moment kN-m*						Mass	
Width W_1 0 -0.05	Height M_1	Pitch F	Length $d_1 \times d_2 \times h$ Max*	C	C_0	M_A		M_B		M_C	LM block kg	LM rail kg/m		
						1 block	Double blocks	1 block	Double blocks	1 block				
25	23.5	17	40	6×9.5×8.5	3000	37 43.7	52.2 66.1	0.479 0.75	2.41 3.71	0.443 0.693	2.23 3.43	0.525 0.665	0.6 0.8	2.9
28	31	21	80	7×11×9	3000	52 64.4	70.1 95.2	0.722 1.31	3.86 6.3	0.667 1.21	3.58 5.83	0.798 1.08	1.1 1.5	4.2
34	33	24.5	80	9×14×12	3000	68.6 86.1	88.6 123	1 1.88	5.49 9.15	0.927 1.73	5.09 8.46	1.2 1.67	1.6 2	6.0
45	37.5	29	105	14×20×17	3090	105 123	142 178	2.19 3.58	10.9 17.5	2.02 3.31	10.1 16.2	2.6 3.44	2.7 3.6	9.5
53	43.5	36.5	120	16×23×20	3060	136 164	180 237	3.17 5.4	16.4 26	2.93 4.99	15.1 24	3.76 4.96	4.5 5.9	14
63	53.5	43	150	18×26×22	3000	208 260	269 370	5.76 10.7	27.7 49.6	5.33 9.88	25.6 45.8	6.66 9.16	7.8 11.0	19.6

Note) Pilot holes for side nipples** are not drilled through in order to prevent foreign material from entering the product. THK will mount grease nipples per your request. Therefore, do not use the side nipple pilot holes** for purposes other than mounting a grease nipple.
In case of oil lubrication, be sure to let THK know the mounting orientation and the exact position in each LM block where the piping joint should be attached.
For the mounting orientation and the lubrication, see [A1-12](#) and [A24-2](#), respectively.
The maximum length under "Length**" indicates the standard maximum length of an LM rail. (See [A1-134](#).)
Static permissible moment*: 1 block: static permissible moment value with 1 LM block
Double blocks: static permissible moment value with 2 blocks closely contacting with each other

Models SVR-RH, SVR-LRH, SVS-RH and SVS-LRH

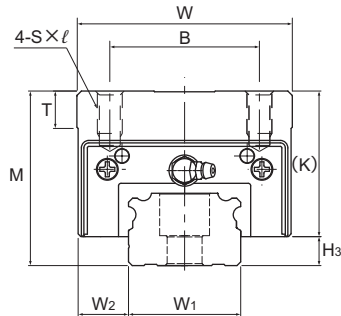

Model No.	Outer dimensions			LM block dimensions													Grease nipple	H ₃
	Height	Width	Length	B	C	S × ℓ	L ₁	T	K	N	f ₀	E	e ₀	D ₀				
	M	W	L															
SVR 35RH SVS 35RH	55	70	109.5	50	50	M8 × 12	79	11.7	46	23.1	19	12	6	5.2	B-M6F	9		
SVR 35LRH SVS 35LRH	55	70	135	50	72	M8 × 12	104.5	11.7	46	23.1	19	12	6	5.2	B-M6F	9		
SVR 45RH SVS 45RH	70	86	138.2	60	60	M10 × 17	105	14.7	58.4	31.9	26	16	8.5	5.2	B-PT1/8	11.6		
SVR 45LRH SVS 45LRH	70	86	171	60	80	M10 × 17	137.8	14.7	58.4	31.9	26	16	8.5	5.2	B-PT1/8	11.6		
SVR 55RH SVS 55RH	80	100	163.3	75	75	M12 × 18	123.6	17.7	66	33.6	27	16	10	5.2	B-PT1/8	14		
SVR 55LRH SVS 55LRH	80	100	200.5	75	95	M12 × 18	160.8	17.7	66	33.6	27	16	10	5.2	B-PT1/8	14		

Model number coding

SVR35 RH 2 QZ TTHH C0 +920L H T - II

Model No.

Type of LM block

With QZ Lubricator

Contamination protection accessory symbol (*1)

LM rail length (in mm)

Radial clearance symbol (*2)

Normal (No symbol)

Light preload (C1)

Medium preload (C0)

Symbol for LM rail jointed use

Accuracy symbol (*3)

Normal grade (No Symbol)/High accuracy grade (H)

Precision grade (P)/Super precision grade (SP)

Ultra precision grade (UP)

Symbol for No. of rails used on the same plane (*4)

No. of LM blocks used on the same rail

(*1) See contamination protection accessory on **A1-494**. (*2) See **A1-70**. (*3) See **A1-76**. (*4) See **A1-13**.

Note) This model number indicates that an LM block and an LM rail constitute one set (i.e., the required number of sets when 2 rails are used in parallel is 2).

Those models equipped with QZ Lubricator cannot have a grease nipple. When desiring a grease nipple for a model attached with QZ, contact THK.

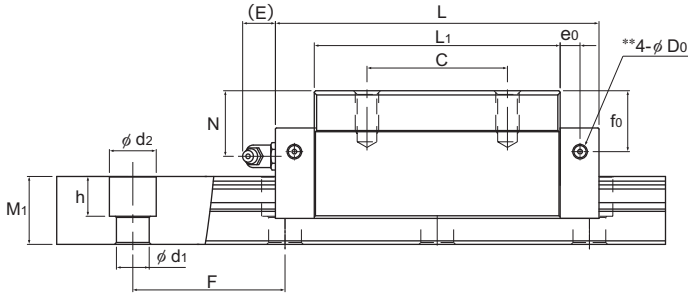

Unit: mm

LM rail dimensions							Basic load rating		Static permissible moment kN-m*					Mass	
Width W_1 0 -0.05	Width W_2	Height M_1	Pitch F	Pitch $d_1 \times d_2 \times h$	Length Max^*	C kN	C_0 kN	M_A		M_B		M_C	LM block kg	LM rail kg/m	
								1 block	Double blocks	1 block	Double blocks	1 block			
34	18	24.5	80	9×14×12	3000	89.6 68.6	116 88.6	1.26 1	6.91 5.49	0.769 0.927	4.2 5.09	1.64 1.2	1.5	6.0	
34	18	24.5	80	9×14×12	3000	112 86.1	160 123	2.35 1.88	11.5 9.15	1.42 1.73	6.91 8.46	2.26 1.67	2	6.0	
45	20.5	29	105	14×20×17	3090	138 105	186 142	2.76 2.19	13.7 10.9	1.67 2.02	8.3 10.1	3.5 2.6	3.1	9.5	
45	20.5	29	105	14×20×17	3090	161 123	233 178	4.52 3.58	22.1 17.5	2.74 3.31	13.4 16.2	4.6 3.44	4.1	9.5	
53	23.5	36.5	120	16×23×20	3060	177 136	235 180	3.99 3.17	20.6 16.4	2.42 2.93	12.4 15.1	5.07 3.76	4.7	14	
53	23.5	36.5	120	16×23×20	3060	214 164	309 237	6.8 5.4	32.7 26	4.1 4.99	19.7 24	6.67 4.96	6.2	14	

Note) Pilot holes for side nipples** are not drilled through in order to prevent foreign material from entering the product. THK will mount grease nipples per your request. Therefore, do not use the side nipple pilot holes** for purposes other than mounting a grease nipple.

In case of oil lubrication, be sure to let THK know the mounting orientation and the exact position in each LM block where the piping joint should be attached.

For the mounting orientation and the lubrication, see [A1-12](#) and [A24-2](#), respectively.

The maximum length under "Length*" indicates the standard maximum length of an LM rail. (See [A1-134](#).)

Static permissible moment*: 1 block: static permissible moment value with 1 LM block

Double blocks: static permissible moment value with 2 blocks closely contacting with each other

Models SVR-CH, SVR-LCH, SVS-CH and SVS-LCH

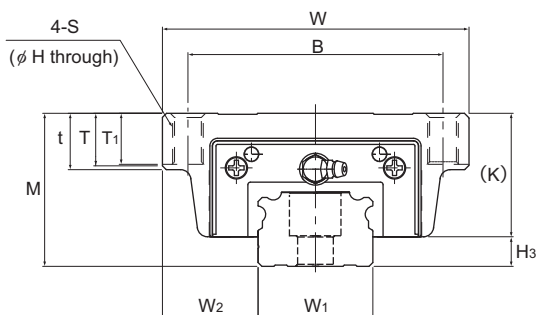

Model No.	Outer dimensions			LM block dimensions																Grease nipple	H ₃
	Height	Width	Length	B	C	S	H	L ₁	t	T	T ₁	K	N	f ₀	E	e ₀	D ₀				
	M	W	L	B	C	S	H	L ₁	t	T	T ₁	K	N	f ₀	E	e ₀	D ₀		H ₃		
SVR 35CH SVS 35CH	48	100	109.5	82	62	M10	8.5	79	20	19	16	39	16.1	12	12	6	5.2	B-M6F	9		
SVR 35LCH SVS 35LCH	48	100	135	82	62	M10	8.5	104.5	20	19	16	39	16.1	12	12	6	5.2	B-M6F	9		
SVR 45CH SVS 45CH	60	120	138.2	100	80	M12	10.5	105	22	20.5	20	48.4	21.9	16	16	8.5	5.2	B-PT1/8	11.6		
SVR 45LCH SVS 45LCH	60	120	171	100	80	M12	10.5	137.8	22	20.5	20	48.4	21.9	16	16	8.5	5.2	B-PT1/8	11.6		
SVR 55CH SVS 55CH	70	140	163.3	116	95	M14	12.5	123.6	24	22.5	22	56	23.6	17	16	10	5.2	B-PT1/8	14		
SVR 55LCH SVS 55LCH	70	140	200.5	116	95	M14	12.5	160.8	24	22.5	22	56	23.6	17	16	10	5.2	B-PT1/8	14		

Model number coding

SVR45 LCH 2 QZ TTHH C0 +1200L P T -II

Model No.

Type of LM block

With QZ Lubricator

Contamination protection accessory symbol (*1)

LM rail length (in mm)
Radial clearance symbol (*2)
Normal (No symbol)
Light preload (C1)
Medium preload (C0)

Symbol for LM rail jointed use

Symbol for No. of rails used on the same plane (*4)

Accuracy symbol (*3)

Normal grade (No Symbol)/High accuracy grade (H)
Precision grade (P)/Super precision grade (SP)
Ultra precision grade (UP)

No. of LM blocks used on the same rail

(*1) See contamination protection accessory on **A1-494**. (*2) See **A1-70**. (*3) See **A1-76**. (*4) See **A1-13**.

Note) This model number indicates that an LM block and an LM rail constitute one set (i.e., the required number of sets when 2 rails are used in parallel is 2).

Those models equipped with QZ Lubricator cannot have a grease nipple. When desiring a grease nipple for a model attached with QZ, contact THK.

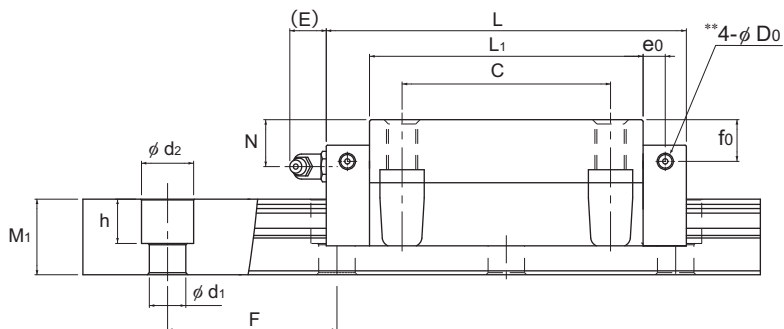

Unit: mm

LM rail dimensions						Basic load rating		Static permissible moment kN-m*					Mass	
Width W ₁ 0 -0.05	W ₂	Height M ₁	Pitch F	Length Max*	C	C ₀	M _A		M _B		M _C	LM block kg	LM rail kg/m	
							1 block	Double blocks	1 block	Double blocks	1 block			
34	33	24.5	80	9×14×12	3000	89.6 68.6	116 88.6	1.26 1	6.91 5.49	0.769 0.927	4.2 5.09	1.64 1.2	1.7	6.0
34	33	24.5	80	9×14×12	3000	112 86.1	160 123	2.35 1.88	11.5 9.15	1.42 1.73	6.91 8.46	2.26 1.67	2.2	6.0
45	37.5	29	105	14×20×17	3090	138 105	186 142	2.76 2.19	13.7 10.9	1.67 2.02	8.3 10.1	3.5 2.6	3.3	9.5
45	37.5	29	105	14×20×17	3090	161 123	233 178	4.52 3.58	22.1 17.5	2.74 3.31	13.4 16.2	4.6 3.44	4.3	9.5
53	43.5	36.5	120	16×23×20	3060	177 136	235 180	3.99 3.17	20.6 16.4	2.42 2.93	12.4 15.1	5.07 3.76	5.1	14
53	43.5	36.5	120	16×23×20	3060	214 164	309 237	6.8 5.4	32.7 26	4.1 4.99	19.7 24	6.67 4.96	6.6	14

Note) Pilot holes for side nipples** are not drilled through in order to prevent foreign material from entering the product.

THK will mount grease nipples per your request. Therefore, do not use the side nipple pilot holes** for purposes other than mounting a grease nipple.

In case of oil lubrication, be sure to let THK know the mounting orientation and the exact position in each LM block where the piping joint should be attached.

For the mounting orientation and the lubrication, see **A1-12** and **A24-2**, respectively.

The maximum length under "Length**" indicates the standard maximum length of an LM rail. (See **A1-134**.)

Static permissible moment*: 1 block: static permissible moment value with 1 LM block

Double blocks: static permissible moment value with 2 blocks closely contacting with each other

Standard Length and Maximum Length of the LM Rail

Table1 shows the standard lengths and the maximum lengths of model SVR/SVS variations. If the maximum length of the desired LM rail exceeds them, jointed rails will be used. Contact THK for details.

For the G dimension when a special length is required, we recommend selecting the corresponding G value from the table. The longer the G dimension is, the less stable the G area may become after installation, thus causing an adverse impact to accuracy.

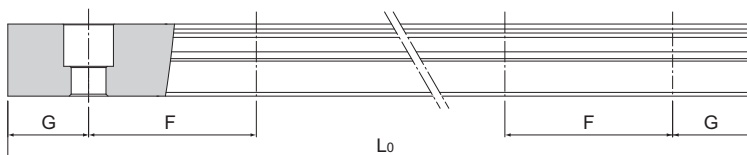

Table1 Standard Length and Maximum Length of the LM Rail for Models SVR/SVS

Unit: mm

Model No.	SVR/SVS 25	SVR/SVS 30	SVR/SVS 35	SVR/SVS 45	SVR/SVS 55	SVR/SVS 65
LM rail standard length (L_0)	230	280	280	570	780	1270
	270	360	360	675	900	1570
	350	440	440	780	1020	2020
	390	520	520	885	1140	2620
	470	600	600	990	1260	
	510	680	680	1095	1380	
	590	760	760	1200	1500	
	630	840	840	1305	1620	
	710	920	920	1410	1740	
	750	1000	1000	1515	1860	
	830	1080	1080	1620	1980	
	950	1160	1160	1725	2100	
	990	1240	1240	1830	2220	
	1070	1320	1320	1935	2340	
	1110	1400	1400	2040	2460	
	1190	1480	1480	2145	2580	
	1230	1560	1560	2250	2700	
	1310	1640	1640	2355	2820	
	1350	1720	1720	2460	2940	
	1430	1800	1800	2565	3060	
	1470	1880	1880	2670		
	1550	1960	1960	2775		
	1590	2040	2040	2880		
	1710	2200	2200	2985		
	1830	2360	2360	3090		
	1950	2520	2520			
2070	2680	2680				
2190	2840	2840				
2310	3000	3000				
2430						
2470						
Standard pitch F	40	80	80	105	120	150
G	15	20	20	22.5	30	35
Max length	3000	3000	3000	3090	3060	3000

Note1) The maximum length varies with accuracy grades. Contact THK for details.

Note2) If jointed rails are not allowed and a greater length than the maximum values above is required, contact THK.